

SpaceStation and SpaceCom



Instructions for Use

Rx only

US Valid for software 012U

B | BRAUN

CONTENTS

Patient Safety	4
Chapter 1 The SpaceStation in Detail	8
1.1 Fastening a Single SpaceStation	9
1.2 Assembly and Disassembly of Pillars	10
1.3 Combining Individual SpaceStations	10
Chapter 2 Combination of Pumps within a SpaceStation	13
Chapter 3 Inserting and Removing Individual Pumps	14
Chapter 4 SpaceCover Standard	15
Chapter 5 SpaceCover Comfort.....	15
5.1 Operating Elements and Status Display on the SpaceCover	16
5.1.1 Display of Battery Condition	16
5.1.2 Switching On/Off	17
5.1.3 Volume Control	17
5.1.4 Brightness Sensor	17
5.1.5 Battery Maintenance Program	18
5.1.6 Status Display	18
5.1.7 Self check during start up	18
Chapter 6 Interfaces for Data Communication.....	19
6.1 Intended Use	19
6.2 The connectors of SpaceCom	20
6.2.1 SpaceCom connectors (up to serial number 9.999).....	20
6.2.2 SpaceCom connectors (since serial number 10.000).....	21
6.3 Status Displays	21
6.4 Inserting and removing battery for SpaceCom	22
6.5 Configuration SpaceCom Interfaces	22
6.6 SpaceOnline, the SpaceCom Web Server Application	23
6.6.1 Setting of a network connection	23
6.6.2 Login.....	23
6.7 Status	24
6.8 Service Menu	25
6.9 Configuration.....	25
6.9.1 User Settings	25
6.9.1.1 Change Password.....	26
6.9.1.2 Change Username	26
6.9.1.3 Change access authorization.....	26
6.9.2 WLAN and Ethernet Settings	27
6.9.3 BCC Protocol Settings.....	27
6.9.4 Battery Settings.....	28
6.9.5 Database Settings.....	28
6.9.6 Simple Network Time Protocol settings.....	28
6.9.7 File Transfer Protocol Settings.....	28
6.9.8 Maintenance and Software Update.....	29
6.9.8.1 B. Braun SpaceStation with SpaceCom (since serial number 10.000) ...	29
6.9.8.2 B. Braun SpaceStation with SpaceCom (up to serial number 9.999)	29
6.9.9 OnlineSuite.....	30
6.10 Wireless LAN	31
Chapter 7 AutoProgramming.....	33
Chapter 8 Barcode Reader	34
Chapter 9 Service	35
Chapter 10 Maintenance / Disinfecting / Disposal / Rechargeable Batteries.....	36
10.1 Maintenance	36
10.2 Disinfecting	36
10.3 Disposal.....	37
10.4 Rechargeable Batteries	37

Chapter 11	Technical Data	39
	11.1 B. Braun SpaceStation without B. Braun SpaceCom	39
	11.2 B. Braun SpaceStation with B. Braun SpaceCom (since serial number 10.000)	40
	11.3 B. Braun SpaceStation with B. Braun SpaceCom (up to since serial number 9.999) ...	41
	11.4 B. Braun SpaceCover comfort	42
Chapter 12	GNU General Public License	47
Ordering	54

PATIENT SAFETY

Important Information and Notes for Patient Safety

⚠ Attention: Consult accompanying documents!

- Read Instructions for Use prior to use.
- The user must check functional safety and integrity of the Space® System.
- Prior to use check functions of the Space® System: Valid only for Space® System.
- Functional tests and Technical Safety Checks have to be carried out separately for all additional connected devices.
- Check and set up connections to A/C mains and further plug connections.
- Check if A/C mains voltage corresponds to indication on the type plate!
- When connected, check staff call (simulate alarm, staff call must react).

Warnings:

- Space® System is to be used by qualified staff only.
- Space® System is to be used by staff who are familiar with the instructions and device.
- Understanding the Instructions for Use is necessary for proper use of the Space® System.
- The Instructions for Use have to be available at the Space® System.

Proper Use:

- The modular Space® System is made for treatment of a single patient. It is especially designed for use on Intensive Care Units and Operating Theaters. The Space® System is used in hospitals by qualified physicians and nursing staff.
- Check if the current software and hardware version of the components of the Space® System are the same as this Instructions for Use refers to.
- If using the optional Space® IV Pole, do not use short stands as the center of gravity of the Space® System may change.
- Not to be used adjacent and stacked with other equipment except B. Braun Space® devices.
- Check stability and secure position, especially when fastening the system to the Space® IV Pole.
- Prevent the Space® IV Pole from rolling away on horizontal surfaces by using the wheel locks. If there is an incline of more than 5°, additional locking is necessary.
- When the pumps in the Space® System are switched off the control systems are not active. Therefore, close roller clamp or selector valve at the connection point to prevent uncontrolled backflow.
- Do not plug the power supply lead into the socket until the whole system is connected/installed.
- The Space® System is designed for operation with a single power supply connection per pillar.
- All configurations must comply with IEC/EN 60601-1-1.
- Possible explosion hazard if used in presence of flammable anesthetics!
- Use only compatible combinations of equipment, accessories, working parts and disposables.

- Do not touch the SpaceStation connectors and the patient simultaneously.
- Use only original spare parts. Functional safety is only guaranteed if the manufacturer recommended responsible compatible disposables are used.
- Carefully read the Instructions for Use of the infusion pumps and infusion syringe pumps used.
- Operation of infusion pumps and infusion syringe pumps should be done only by specially trained staff.
- The user must make sure the pumps and other components of the system are locked correctly.
- Do not place items on the pumps. Avoid leaning on the pumps!
- The connecting leads must be laid so that people do not stumble over them and work with the Space® System is not hampered.
- Do not place disposable near the connections of the pumps – use hose routings.
- Make sure the pumps are inserted and removed correctly.

Transport:

- With max. 4 pumps. Be especially careful when a patient is connected. Avoid external mechanical action!

Only for use of:

- Infusomat® Space®
- Perfusor® Space®
- SpaceCom

 **Caution:** Only use combined with approved devices/accessories by the manufacturer, otherwise this may lead to higher emission or reduced immunity.

- Some components have further Instructions for Use or assembly instructions, which need to be observed.
- Therapeutic or diagnostic conclusions must not be based exclusively on values displayed on infusion pumps or data available via interfaces.
- The Space® System should only be operated in areas which are well protected against vibration, dust corrosive and explosive gases, extreme temperatures and humidity. To guarantee sufficient air circulation for cooling the system, there should be at least 5 cm (1.97 inches) of clear space around the system. Do not cover the ventilation slots. The equipment must be free of condensate during operation.
- When equipment with high electro-magnetic radiation is used at the same time (e.g. digital telephones, X-ray apparatus, MRI, etc.) interference may occur. This may lead to display trouble or implausible values may be indicated. If these problems are due to electro-magnetic interferences, the following measures may help to avoid or solve them:
 - Extend distance between source of interference and the medical product.
 - Alter position of power supply leads, connection leads and electrodes.
- The EMC-limits (electro-magnetic compatibility) according to IEC/EN 60601-1-2 and IEC/EN 60601-2-24 are maintained. If the equipment is operated in the vicinity of other equipment which may cause high levels of interference (e.g. HF

surgical equipment, nuclear spin tomography units, mobile telephones) may be disturbed. Maintain the recommended protective distances for these devices.

- The Space® System should not be exposed to excessive magnetic fields (e.g. in an MRI room). If necessary, longer infusion lines can be used. When using a defibrillator, precautions must be observed which can be found in the documentation for the defibrillator.

 **Caution:** The SpaceStation is unsafe to use in proximity to magnetic resonance imaging (MRI) equipment.

- In any case of central alarm (e.g. from staff call) it is necessary to check which infusion pump caused the alarm. Only the specified alarm caused by the infusion pump is relevant for safety.
- Direct contact of the connectors of the SpaceStation during operation can lead to malfunction due to electrostatic discharge.



Parallel infusion:

Compared to single infusions increased bolus volumes and alarm delay times may occur!

Therefore:

- If possible, select low pressure settings.
- Pay attention to bigger bolus volumes and alarm delay times.
- When removing obstruction, do not let the bolus reach the patient.
- A bolus reduction may lead to an underdosage of the drug when starting the infusion again.
- The bolus reduction may lead to dosage variations.
- Higher personal supervision with critical drugs.
- Immediate reaction in case of alarm!
- When switching off a pump temporarily, bolus administration is possible due to enrichment of concentration at reduced flow.

International safety standards:

The Space® System complies with:

- IEC/EN 60601-1
- IEC/EN 60601-1-1
- IEC/EN 60601-1-2
- IEC/EN 60601-2-24

and is CE marked in compliance with EU-Directive 93/42.

B. Braun Melsungen AG is certified according to DIN EN ISO 9001 and DIN EN ISO 13485.

This certification also includes maintenance and service.

The B. Braun Space® System is a flexible docking and communication system for the medical workplace, in particular the intensive medical care, which substantially contributes to the safety of its patients.

It accommodates the infusion and infusion-syringe pumps Infusomat® Space® and Perfusor® Space®, whose application is decided by the medical professional based upon guaranteed characteristics and technical data. The pillar and mounting system synchronized system components enables the individualized workplace design. The Space® System is flexible due to fast and space saving assembly and disassembly as well as the possibility to use it as a mobile, wall or ceiling unit.

For further descriptions as well as assembly resp. disassembly please see this Instructions for Use.

Transport damages:

Inspection on delivery. Despite careful packaging, the risk of transport damage cannot be entirely prevented. Upon delivery, please check that nothing is missing. Do not use a damaged device. Contact the service department.

Packaging:

Packages are designed in a way that:

- electrostatic charges are prevented
- batteries on printed boards cannot be discharged.

 **Attention:** If this equipment is modified, appropriate inspection and testing must be conducted to ensure continued safe use of the equipment.

This device/firmware contains components that are licensed under the GNU General Public License version 2 (see chapter 12). To receive the source code of these components as required by that license, please get in contact with your local B. Braun Representative.

THE SPACESTATION IN DETAIL

SpaceStation serves to accommodate up to four infusion and infusion syringe pumps. The single SpaceStations can be assembled to form one or up to three pillars which are separated from each other. The individual pillars require their own mains supply and are interconnected with each other via special extension cables. Every pillar must be closed with a cover, SpaceCover Comfort, to ensure safe and complete system functionality.

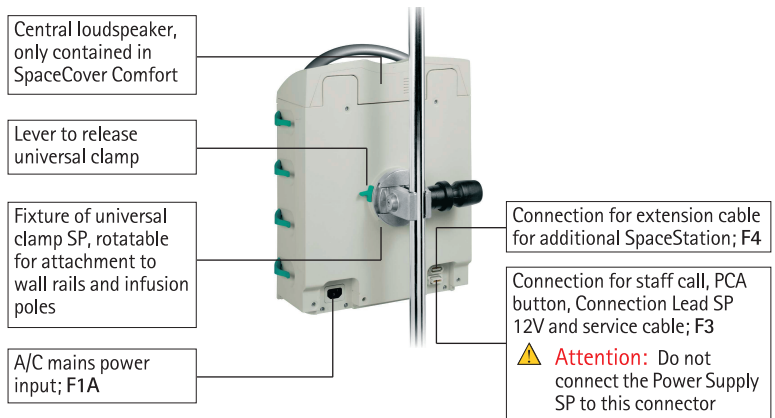
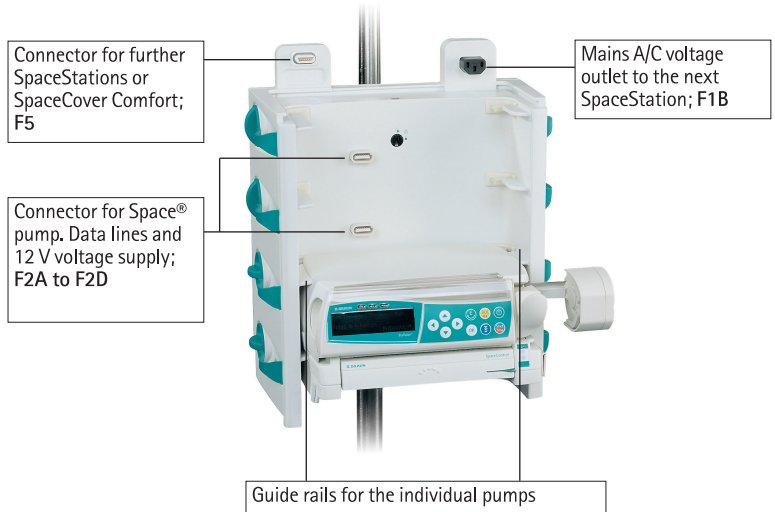

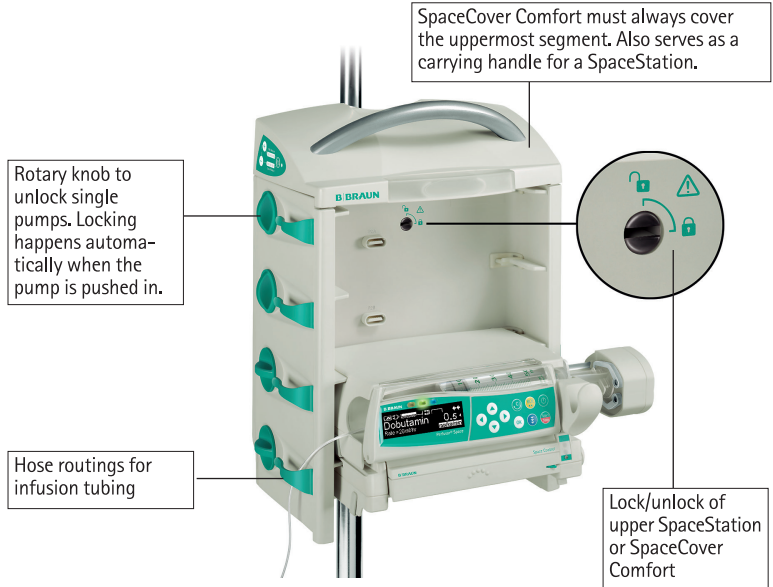

⚠ Attention: Every SpaceStation, or one pillar consisting of several SpaceStations, must be covered with SpaceCover Comfort. The SpaceCover Comfort protects the upper connections from humidity and damage and ensures perfect system functionality. The SpaceStation and the individual pump are connected to each other via the connectors F2A to F2D. The plugs are to be protected from damage and humidity.

Note: Install the SpaceStation so that it is easy to disconnect from the mains power. For this purpose pull out the mains plug.

⚠ Caution: Do not touch the SpaceStation connectors and the patient simultaneously.

1.1 Fastening a Single SpaceStation

Every single SpaceStation can be attached to infusion poles and vertical tubes, e.g. pendants suspension, as well as to horizontal wall rail systems according to EN 1789 without need of any further adapters or assembly auxiliaries. The rear universal clamp can be rotated and has a quick-action mechanism. By pulling the release ring back, the slide can be moved freely and prepositioned. Now the SpaceStation can be definitely fixed by means of the set screw.

- ⚠ Attention:** Make sure that the SpaceStation is fastened correctly and safely after assembly. Do not use tools to tighten the screw!

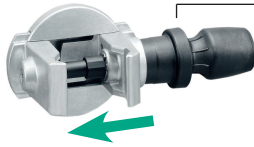

By pulling the **release ring** back, the slide can be moved freely for prepositioning.

To release, first loosen the clamp by turning the adjusting knob a half turn and then pull the release ring in order to loosen the pole clamp using the quick gripping mechanism.



1.2 Assembly and Disassembly of Pillars

The upper segment is pushed onto the lower segment from the front and locked together with the locking button in the lower segment.

Note: A coin can be used to turn the locking button to the locked or unlocked position.

To release, turn the locking button in the corresponding position and take out the upper segment to the front.

- ⚠ Attention:** Every single SpaceStation must be fixed to an IV Pole or a fastening tube by means of a fixation clamp.

1.3 Combining Individual SpaceStations

To mount one or multiple pillars the single SpaceStations can be assembled easily and without any difficulties without requiring any special assembly tools.

The admissible combinations are listed in the following table:

	1 Pillar	2 Pillars		3 Pillars		
	A	A	B	A	B	C
SpaceCover Comfort	1	1	(1)	1	(1)	(1)
SpaceCover Standard	(1)	(1)	1	(1)	1	1
SpaceStation	1 ... 6	1 ... 5	1 ... 5	1 ... 4	1 ... 4	1 ... 4
Restriction	$A \leq 6$	$\sum A + B \leq 6$		$\sum A + B + C \leq 6$		

(x) alternative usage possible A,B,C number of SpaceStation in one pillar

⚠ Attention: Other configurations, such as more than three pillars or exceeding the number of SpaceStations within a pillar, are not permitted and result in configuration error.

If a system consists of several pillars, these should be arranged logically and physically from left to right.



Extension lead SP 60cm (23.62 inches) or 120cm (47.24 inches).
The lead is connected to F4 in pillar 1 and then to F3 in pillar 2.

⚠ Attention: Before connecting or disconnecting the Extension lead please unplug the system from mains power. Not doing this will lead to corrupt data transmission to external systems and wrong display of data in SpaceOnline and Space® OnlineSuite.

⚠ Attention: If the pillars will not be connected as described above, interchanging F4 and F3, there is a wrong topological representation in SpaceOnline and wrong addressing in the BCC protocol.

Every single pillar must be covered with a SpaceCover Comfort. If with a two or three pillars build up and only one SpaceCover Comfort is used in this combination all alarms and status information are displayed at this Cover. In case every pillar is covered with a SpaceCover Comfort the status and alarm information are shown at the each corresponding cover.

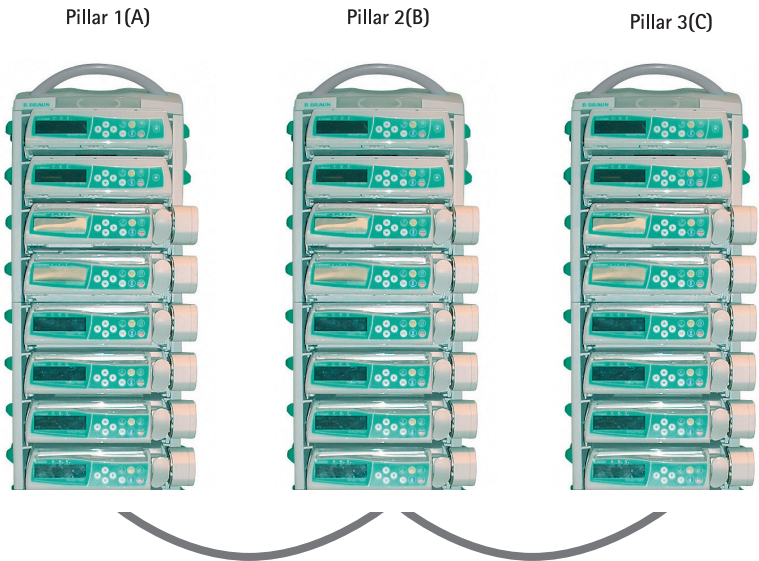

Extension lead SP 60cm (23.62 inches) or 120cm (47.24 inches).
The lead is connected to F4 in pillar 1 and then to F3 in pillar 2. Pillar 2 and 3 are interconnected with each other via F3 and F4.

⚠ Attention: Before connecting or disconnecting the Extension lead please unplug the system from mains power. Not doing this will lead to corrupt data transmission to external systems and wrong display of data in OnlineSuite.

COMBINATION OF PUMPS WITHIN A SPACESTATION

The following pumps and modules can be combined within a SpaceStation:

- 4 pumps; Infusomat® or Perfusor® Space® and optional SpaceCom



- ⚠ **Attention:** Danger of tipping !
An operation as tabletop unit is **not allowed**. Operation is **only allowed** if mounted on a stable infusion pole.

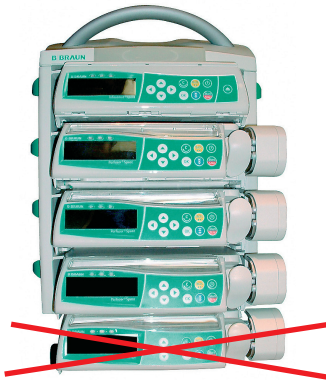

- ⚠ **Attention:** The operation of a fifth pump mounted under the lowest pump in the system is not allowed.

INSERTING AND REMOVING INDIVIDUAL PUMPS

⚠ Attention: Before inserting a pump please ensure the vertical position of the side rotary knob.

The guide rails of the SpaceStation must engage in the guide grooves of the pump. The pump is then pushed with light pressure into the SpaceStation. The pump is automatically locked in the system. The locking is to be recognized by the horizontal position of the side rotary knob.



To release, turn the knob clockwise in the vertical position and remove the pump. After release the pump is held in the SpaceStation by the guide rails, but can drop easily due to strong vibrations or during transport.

⚠ Attention: If a SpaceStation is used to transport infusion pumps make sure that the pumps are correctly seated in the system.

⚠ Attention: After connecting a pump, the blue LED starts flashing for a short time. In case the blue LED is illuminated constantly, a non critical fault is detected. By disconnecting and connecting the pump again, the fault could disappear, observe blue LED. If the blue LED stays illuminated please inform the technical service. The pump can still be used but the status is not shown at the SpaceCover comfort, green/yellow/red LED at cover, and communication with external systems, PDMS, SpaceOneView, or staff call, is not working anymore and the pump will no longer communicate with the SpaceStation or any other external devices (ie PDMS, EMR/EHR systems, staff call, etc.). Pump Status information can only be viewed on the pump's display.

SPACECOVER COMFORT

SpaceCover Comfort is required when using the SpaceStation. It connects to the top section of the SpaceStation and acts as the communication display for all Space® Pumps inserted in the SpaceStation. Mounted on the front of the cover is a large and clearly visible status and alarm display. All status and alarm conditions of the pumps within the system as well as of the pumps themselves are displayed. The following conditions can be indicated:

- green -> OK; at least one pump in operation
- yellow -> prealarm of one pump in the system
- red -> alarm of a pump in the system

Details concerning the single prealarms and alarms are given in the corresponding instructions for use of the pumps.

In addition, a rechargeable battery (the same as with the pumps) can be inserted in the SpaceCover Comfort. This rechargeable battery ensures complete system functionality in case of transport and even at an interruption of the voltage supply. Furthermore a loudspeaker is integrated in the SpaceCover Comfort to output the alarms of the pumps. The volume can be adjusted in 4 steps via the operating elements.



5.1 Operating Elements and Status Display on the SpaceCover

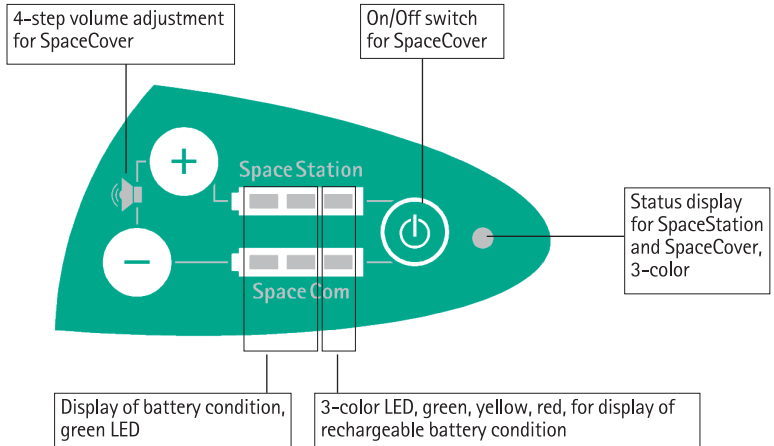

































5.1.1 Display of Battery Condition

The display elements indicate the condition of the rechargeable battery in the SpaceCover and the SpaceCom. The rechargeable battery for SpaceCom is available as an option.

The following conditions are indicated

	LED left	LED middle	LED right
> 75% capacity			
> 50% capacity			
> 25% capacity			
≤ 25% capacity			
< 30 min operating time			
< 3 min operating time			
Maintenance required			
Maintenance active (capacity > 75%)			
Maintenance active (capacity > 50%)			
Maintenance active (capacity > 25%)			
Maintenance active (capacity < 25%)			

Rechargeable battery SpaceCom (is only displayed when rechargeable battery is installed)

	LED left	LED middle	LED right
> 75% capacity			
> 50% capacity			
> 25% capacity			
≤ 25% capacity			
Battery flat, switched over to SpaceStation battery			
Maintenance required			
Maintenance active (capacity > 75%)			
Maintenance active (capacity > 50%)			
Maintenance active (capacity > 25%)			
Maintenance active (capacity < 25%)			
Error, change battery			

Rechargeable battery SpaceStation

Battery pre- and end alarms can be acknowledged with the buttons of the volume control "+" and "-". Thereby the audible alarm is prevented, the optical alarm is still displayed. Battery alarms are automatically acknowledged when the system is reconnected to the mains.

5.1.2 Switching On /Off

The On-/Off-switch is only operable in battery mode. When the system is connected to the A/C mains voltage, the system is always activated.

 **Attention:** When the system is not needed and not connected to the A/C mains voltage, the SpaceCover should be switched off.

To switch off the system the on/off switch has to be pressed and held for three seconds. The status LED will flash for 5 seconds and then go out.

5.1.3 Volume Control

The volume of the loudspeaker installed in the SpaceCover can be controlled with the buttons "+" and "-". The setting is done in 4 steps, after every new step a high beep signal with the new loudness is given. If the maximum or minimum setting is reached a deep beep is given. The last setting is saved when the system is switched off.

5.1.4 Brightness Sensor

Every SpaceCover Comfort is equipped with a brightness sensor that adapts the brightness of the alarm display in the cover to the environment. The brightness cannot be adjusted manually.

5.1.5 Battery Maintenance Program

To guarantee maximum battery capacity and at the same time a long service life, a battery maintenance program is integrated in the system. The battery maintenance is displayed automatically dependent on the operation of the unit. The battery maintenance program can only be initiated when the system is connected to the A/C mains. When the program is running, the unit should not be used for transport purposes because the complete battery running time is not guaranteed. The battery maintenance program can be triggered separately for the battery of the SpaceCover and SpaceCom.

When maintenance is necessary the status diode green/green/yellow of the respective battery lights up. The maintenance program is started by pressing the On/Off button and the "-" button for the SpaceCom or the "+" button for the SpaceCover simultaneously. During maintenance all green LEDs are flashing and go out when the capacity reduces. When the maintenance program is completed, the batteries are recharged.

 **Attention:** When battery maintenance is carried out the unit should not be used for transport purposes because the complete battery running time is not guaranteed.

5.1.6 Status Display

green	->	The system is operated with A/C mains voltage
yellow	->	The system is operated by battery
flashing red	->	Wrong configuration, check the system setup
red	->	Unrecoverable error, exchange cover.

5.1.7 Self check during start up

During the start up of the SpaceCover comfort a self check is started automatically. The three LED at the front side are tested in the order red, yellow, green and after this the status indicators of SpaceStation and SpaceCom are tested. All green, yellow and red according to "Display of battery condition"

If one of the front side alarm indicator is defective the yellow alarm LED and the lateral red status LED are illuminated, see 5.1.6.

INTERFACES FOR DATA COMMUNICATION

The SpaceStation requires the optional SpaceCom module in order to interface and communicate with external Patient Data Management Systems, PDMS.

Existing SpaceStations can be upgraded with SpaceCom or the SpaceStation can be ordered with SpaceCom installed. SpaceStation with SpaceCom functions as a central communication interface for all pumps in the system.

For further details about SpaceCom refer to the following paragraphs. Detailed and supplementary information concerning the communication protocol BCC can be requested separately. SpaceCom provides different interfaces, like Ethernet RJ45, RS232, USB Master for data communication and for the connection of accessories. For wireless data transfer a Wireless LAN Adapter can be integrated into SpaceCom. For central access to data of the infusion pumps a web server is integrated, which can be accessed using a standard internet browser.

 **Attention:** SpaceCom with software F/G is incompatible to Space® pumps and SpaceCom with previous software versions. This results in a faulty transfer of parameters in the BCC Protocol and the display in SpaceOnline. Please ensure that only pumps with software version F/G or U are operated together with SpaceCom. Please ensure that all pumps within a system have the same version of software.

 **Attention:** In case the system structure of a workplace is modified, see Combining Individual SpaceStations, a reboot of SpaceCom is required.

6.1 Intended Use

SpaceCom is used to connect external devices for the data documentation in a Patient Data Management System, PC or USB memory stick.

 **Attention:** Therapeutic or diagnostic conclusions must not be based on values delivered by SpaceCom and their display on a Patient Data Management System or in the web application. In particular the interpretation of alarms does not release the operator from observing the local alarms at the pumps.

Equipment connected to SpaceCom must comply with the respective IEC or ISO standards (e.g. IEC 60950 for data processing equipment or IEC 1010 General Safety Requirements for Electrical Equipment).

Furthermore, all configurations shall comply with the requirements for medical electrical systems (see IEC 60601-1-1 or clause 16 of the 3Ed. of IEC 60601-1, respectively). Anybody connecting additional equipment to medical electrical equipment configures a medical system and is therefore responsible that the system complies with the requirements for medical electrical systems. Attention is drawn to the fact that local laws take priority over the above mentioned requirements.

6.2 The connectors of SpaceCom

The RJ45 plug of the Ethernet socket is protected against unintentional removing by a mechanical lock. To remove the plug, slightly press the cap of the plug cover against the plug. This opens the mechanical lock and the plug can be removed.

6.2.1 SpaceCom connectors (SpaceStation with SpaceCom up to serial number 9.999)

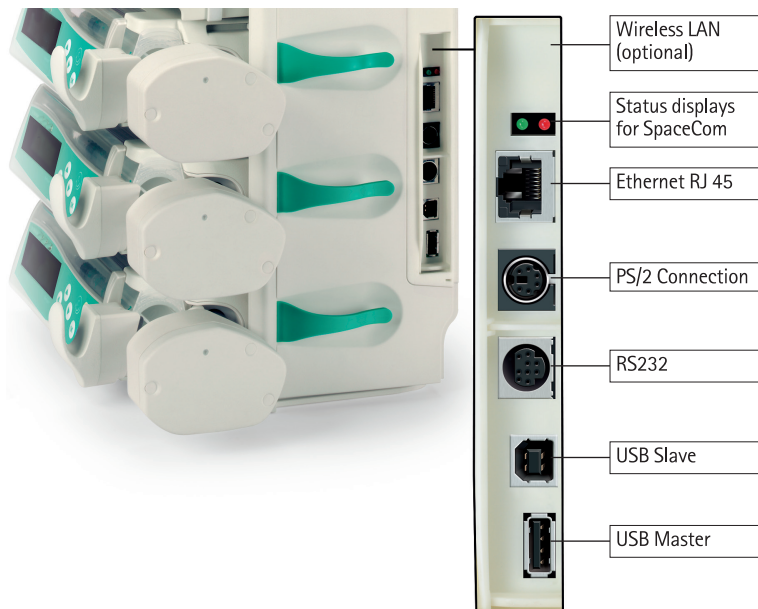

6.2.2 SpaceCom connectors (SpaceStation with SpaceCom since serial number 10.000)

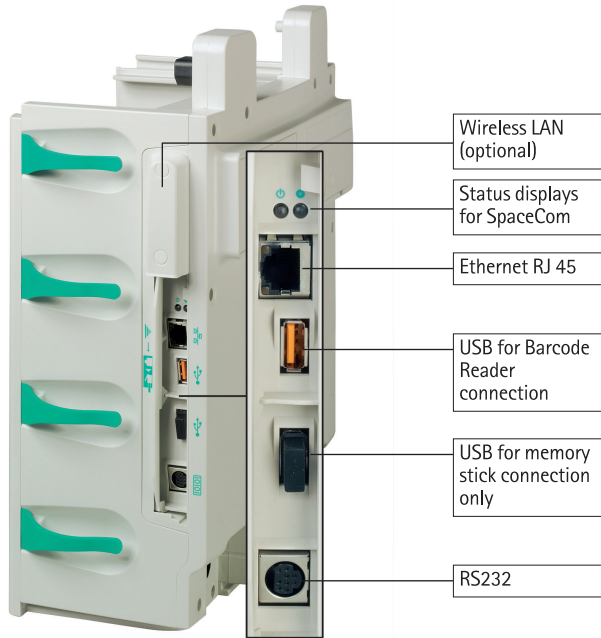

6.3 Status Displays

In SpaceCom there are two status displays showing the operating status. The green LED signals the operating status. The red LED shows errors. For status indications please refer to the following table:

	green LED	red LED
System starting, not yet ready		
SpaceCom is ready		
Error during operation		

After starting the system, the red LED will remain on for approximately 60 seconds and then turn off. If the red LED remains ON, there is an error with the system. To remedy the error try re-starting the system. If the red LED remains on, please contact your B. Braun Service Representative.

6.4 Inserting and removing battery for SpaceCom

Use a coin to open the battery compartment. Insert the battery and secure it in place by pressing the green hook upwards. To remove the battery pull the green hook down.

Battery operation of SpaceCom is only possible if an additional battery is used in SpaceCover Comfort.

6.5 Configuration SpaceCom Interfaces

SpaceCom can be configured via a web access. Default IP address for the Ethernet port is 192.168.100.41. The following parameters and settings can be adjusted:

Parameter	Setting	Settings ex works
IP address Ethernet	Static	192.168.100.41
	DHCP	
	Subnet mask	255.255.255.0
	Gateway	
IP address WLAN	Static	
	DHCP	
	Subnet mask	
	Gateway	
Encoding	WEP	not active
	WPA / WPA2	not active
	TKIP	not active
Communication protocol	BCC	Version 3.26
RS232	Baudrate	9600 8N1

- ⚠ **WARNING:** WEP and WPA encryptions are vulnerable and should not be used. Older encryption methods should be upgraded to the most secure wireless encryption available (i.e. WPA2 or better).
- ⚠ **Attention:** Make sure that the IP address used in SpaceCom is unique within the hospital network and check the correct communication with the PDMS prior to clinical use.
- ⚠ **Attention:** Although the listed wireless encryption standards are supported and available for use, B. Braun recommends use of WPA2 or better encryption.

6.6 SpaceOnline, the SpaceCom Web Server Application

Additional access to the infusion pump data is possible via SpaceOnline. A web server integrated in SpaceCom provides different web pages. Access is protected by a password which offers personal, care unit, or hospital-wide access control. It is recommended to change the default login after installation. Please refer chapter 6.6.2 for detailed information.

⚠ Attention: The data values displayed on the web sites and in particular, the infusion pump alarms, do not release the user from responding to the local alarm displays at the infusion pump. Therapeutic and diagnostic decisions must not be made on the basis of the displays of the web application. SpaceOnline offers different web pages upon which different data or configurations are possible.

6.6.1 Setting of a network connection

To set a network connection on your PC or PDMS (Client-System) please contact the administrator or the manufacturer of the PDMS.

Please set up the network address of SpaceCom via the Web application. Start an internet browser on your PC and fill in the default address or the newly determined IP address in the address field.

Hint: Always use `http://` when accessing SpaceOnline.

As an alternative to the IP address a name in the file "hosts" can be saved in the client system. Please see the documentation of your client system for details.

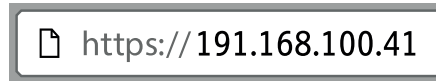

Important: The browser must accept cookies and allow the execution of JavaScript.

Important: SpaceCom only supports Internet Explorer 8.0 or higher as well as Mozilla Firefox web browser version 3 or higher.

6.6.2 Login

The following user names and passwords are predefined:

user name	password	Activated for
status	status	Status page
service	service	Service page
config	config	Configuration page

In order to prevent unauthorized access users are required to change the individual passwords immediately after your initial login.

The system will automatically prompt the user to change the password.

New passwords must meet the following criteria:

- at least 6 characters in length
- at least one lowercase letter (a-z)
- at least one uppercase letter (A-Z)
- at least one number
- at least one special character (-,_,#+=!/?~&%(%)\$)

For further information regarding user system configuration, please refer to the "Configuration – User Settings" section in Chapter 6.9.1.

Note: If a user fails to login after 10 attempts within 1 minute, the system will display an error message.

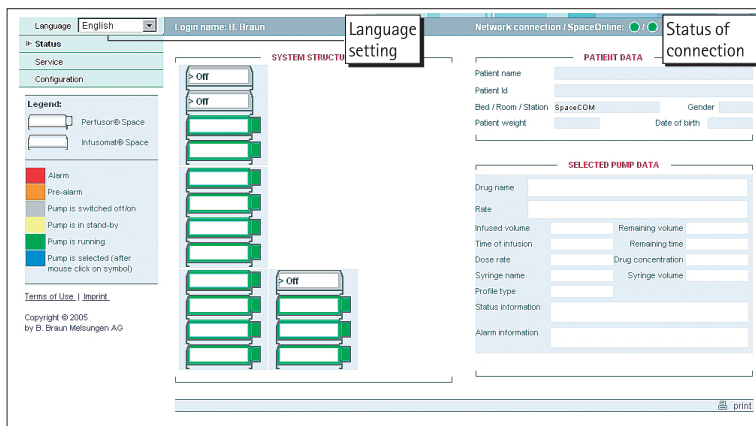







6.7 Status

The Status display shows infusion pump data and the system status. The representation of the pumps corresponds with the topological configuration in the system. The present status will be displayed according to the legend. If a pump is selected, detailed information will be displayed on the right. Patient information will only be saved in the pump. This is available only with pump software version U and higher. The data of the selected pump will be shown according to the pump software version.



A connection status display is integrated in the header.

The network connection between PC or browser and SpaceOnline is shown and the status of SpaceOnline is monitored using the two status displays, red/yellow/green. The displays change their status dynamically. Should one of the two displays stay red for 15 – 20 sec an error is present and the displayed information is no longer up to date. For details please see table below:

Network connection	Status	Cause of Error
green 	OK, data is up to date	
yellow 	OK, but data could not be updated	Application failed
red 	Connection failed, data not up to date	Network connection failed, check network and SpaceCom
Space® Online		
green 	OK, data is up to date	
yellow 	OK, but data could not be updated	Data from SpaceOnline has not yet been updated
red 	SpaceOnline failed, data not up to date	Internal error in SpaceCom, try to solve by restarting

6.8 Service Menu

The service menu contains technical information about the pumps and the systems for service purposes.

6.9 Configuration

Under configuration user settings and configurations can be done.

6.9.1 User Settings

It is possible to administer the password of individual logins, configure the BCC protocol, and determine the network settings. The care unit ID can also be set.

To restore the factory defaults please select "Restore Factory Defaults after Reboot".

Another option is the use of a USB Memory Stick. On the memory stick, create an empty directory with the name "FactoryDefaults". In addition, it is also possible to create a file which is named FactoryDefaults (no extension). Connect it to the USB Master port of SpaceCom and do a reboot by switching the mains power off and on again. Using FactoryDefaults resets the data of SpaceCom to the initial settings (IP=192.168.100.41).

6.9.1.1 Change password

This menu allows users to change the password as referenced in Chapter 6.6.2. Press "change password" to activate the new settings.

Please enter Username and Password

admin	Username
*****	Password
	New password
	Password confirmation

6.9.1.2 Change user name

The predefined user names can be changed in this menu. However, it is not possible to add new or to delete existing user names.

Please enter Username and Password

admin	Username
*****	Password
	New user name
	User name confirmation

6.9.1.3 Change access authorization

The access authorization can be given for each individual user name. The user access rights can be set and must be confirmed by an appropriate password.

Please enter Username and Password

admin	Username
*****	Password

Access Rights

Status

Service

Configuration

6.9.2 WLAN and Ethernet Settings

SpaceCom offers the possibility to be linked into clinical network infrastructure via wireless LAN (WLAN) or Ethernet. The ethernet supports 10/100 Mbit networks. For the integration into WLAN a USB wireless LAN adapter can be integrated supporting 802.11 B/G/N. Detailed information about the settings are found in the instructions for use of the corresponding wireless card types.



Welcome to the Network Management Interface

Please use the navigation menu on top for advanced options

Quick Start:

Create a new Connection

Connect to an LAN Connection

~LAN-Connections~

0# DefaultEth (active)

Connect to Connection

Connect to a reachable WLAN

~WLAN-Connections~

1# SpaceCom1

~Access Points in reach~

SpaceCom2
Schulung1
DroegeWPA

Connect to Connection

Connect to AccessPoint

Active Connections

Name	IP Address	Subnet Mask	Gateway	Type	Driver	State
DefaultEth.0.nm	192.168.100.41	255.255.255.0	0.0.0.0	802-3-ethernet	mpc52xx-fec	connected

6.9.3 BCC Protocol Settings

SpaceCom provides different communication protocols for data exchange with Patient Data Management Systems. For detailed information about compatible systems, please refer to <http://www.space.bb Braun.com>.

The settings of the baud rate as well as parity, stopbits and databits, comply with the requirements of the PDMS.

Interface: COM1

Baudrate: 57600

Parity: n

Stopbits: 1

Databits: 8

Interface: TCP/IP

Baudrate: 57600

Parity: n

Stopbits: 1

Databits: 8

You also can setup a TCP/IP interface for the communication with SpaceCom via the BCC protocol. In this case the port 4001 is used in SpaceCom. In this case the other settings for the COM-Port are not used.

For further information how to configure the BCC protocol see the separate interface description.

6.9.4 Battery Settings

Here you can determine when the battery maintenance program should be activated. It is given in days and only valid for the SpaceCom battery integrated in the rear panel of the SpaceStation. The settings for the batteries of the pumps and of the SpaceCover comfort are made separately using the service program HiBaSeD.

For further information please refer to chapter "Battery Maintenance Program".

6.9.5 Database Settings

The care unit ID is a feature unique to your system, which appears both in the BCC protocol and on the SpaceOnline display. The care unit ID can have up to 15 characters.

SpaceCOM	Bed ID
----------	--------

6.9.6 Simple Network Time Protocol settings

To synchronize the time stored in SpaceCom you can link SpaceCom to a time server in your network. Fill in the required information and restart SpaceCom.

SNTP settings
(S)NTP settings

Current Time: Sat Feb 15 06:55:44 UTC 2014

Actual File:

Upload Timezone File: [Browse...](#)

(S)NTP Server Address:

[Save changes](#)

6.9.7 File Transfer Protocol Settings

SpaceCom allows to setup a File Transfer Protocol connection. Please enter the required data to enable the File Transfer Protocol server at SpaceCom. The File Transfer Protocol access is for service purpose only. The File Transfer Protocol access requires explicit SSL connection. This has to be supported by the File Transfer Protocol client.

6.9.8 Maintenance and Software Update

Important: Please make sure that "Restore factory defaults after reboot" has been selected while executing a software downgrade.

6.9.8.1 B. Braun SpaceStation with SpaceCom (since serial number 10.000)

SpaceCom offers different possibilities to update the software. In case there is a fault in the configuration, you can reset the software to the default setting by checking the box "Restore factory defaults after reboot" and then clicking on the "Reboot SpaceCom" button.

Uploading firmware and software (complete image) allows the installation of new features on SpaceCom. Choose the new image (firmware) by selecting the correct file from the browser and click on "Update Firmware" to start the installation.

Maintenance and software updates

Board Version: spacecom2
Current Software Version: 012U000010

Restore Factory Defaults after Update

Choose Image:

Please select "Restore Factory Defaults after Update when downgrading to a previous version of the firmware."

Restore Factory Defaults after Reboot

Boot into recovery/fallback image

In the event there is an error during the update process or if there are any corrupt settings in SpaceCom, you can force a reboot of SpaceCom by using a boot recovery. Check the box "Boot into recovery/fallback image" and then click on the "Reboot SpaceCom" button. The default Ethernet IP address is 192.168.100.41. You can start the upload process of a new image again.

6.9.8.2 B. Braun SpaceStation with SpaceCom (up to serial number 9.999)

Select "Prepare Update"

B. BRAUN
SOLUTIONS EXPERTISE

B. Braun SpaceOnline
v1.8.0.0

network connection / SpaceOnline: ● ●

Maintenance and software updates

Board Version: spacecom1
Current Software Version: 005J010010

Clicking the "Prepare Update" button will set the system to update state. Afterwards you will be prompted for the new image. While the update is in progress the system will be unusable. When the update is finished, the system will reboot itself.

Restore Factory Defaults after Reboot

Boot into recovery/fallback image

Load image

- a. The module changes to "Update mode"
- b. Press the button "Browse" and choose the desired image.

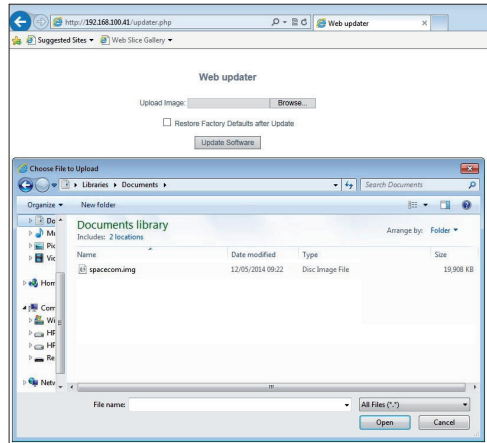

- c. Press "Update Software"

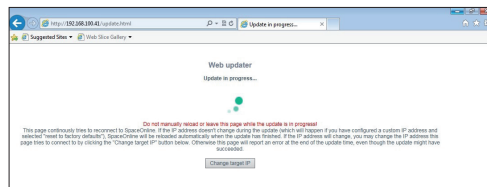

- d. Wait about 10 minutes, until the image is loaded and the module has exited the update.

6.9.9 OnlineSuite

B. Braun Space® OnlineSuite is supported for Software Version U and later. For further information please refer to the Operation Manual of the OnlineSuite. To link to OnlineSuite, no dedicated settings at SpaceCom are required.

6.10 Wireless LAN

- ⚠ **Attention:** The optional WLAN card (2.4 GHz, 100mW & 5 GHz, 100mW) can cause interference with devices in the vicinity. Please observe the necessary minimum distance requirements. When using WLAN, the encryption and authentication should be activated in order to protect the data connection. The card provides WPA/WPA2, WEP, TKIP and AES encryption and authentication listed in the table below for this purpose.
- ⚠ **WARNING:** WEP and WPA encryptions are vulnerable and should not be used. Older encryption methods should be upgraded to the most secure wireless encryption available (i.e. WPA2 or better).
- ⚠ **Attention:** Although the listed wireless encryption standards are supported and available for use, B. Braun recommends use of WPA2 or better encryption.

For more detailed information about the WLAN operation please see the documentation delivered with the upgrade kit WLAN.

Note: When wireless connection has been lost, reboot the device.

The following WLAN settings are available:

WLAN Settings SpaceCom

Name (of profile)

SSID

IPv4 and IPv6

Infrastructure or Ad-hoc

Transmitting Power High/Medium/Low

IPv4:	Method Manual(static) / Auto (DHCP) IP address Subnet Mask Gateway DNS (auto or static)
IPv6:	Method Manual(static) / Auto (DHCP) IP address Prefix Gateway DNS (auto or static)

WLAN Security

Network authentication	- Open Encryption: None WEP 64 (5 alphanumeric / 10 hexadecimal character) WEP128 (13 alphanumeric / 26 hexadecimal character) Network Key
Network authentication	- Shared Encryption: WEP 64 (5 alphanumeric / 10 hexadecimal character) WEP128 (13 alphanumeric / 26 hexadecimal character) Network Key
Network authentication	- WPA/WPA2 Personal (PSK) 8-63 alphanumeric character 64 hexadecimal character Network Key
Network authentication	- WPA/WPA2 Enterprise (EAP) EAP Mode: TLS / TTLS / FAST/ LEAP / PEAPv0-MSCHAPv2

 **WARNING:** WEP and WPA encryptions are vulnerable and should not be used. Older encryption methods should be upgraded to the most secure wireless encryption available (i.e. WPA2 or better).

 **Attention:** Although the listed wireless encryption standards are supported and available for use, B. Braun recommends use of WPA2 or better encryption.

AUTOPROGRAMMING

Please contact your local sales representative in case you like to use AutoProgramming.

BARCODE READER

SpaceCom allows the use of a Barcode Reader to scan information from barcode labels (medication or patient information) and to send the information to a specific pump within the Space® system.

⚠ Attention: Only the barcode reader provided by B. Braun is compatible with Space. In case of any other hardware used a proper operation cannot be guaranteed.

⚠ Attention: The user must verify the data read in via a barcode reader at the pump before confirmation. To allow a clear allocation of a drug to a patient it is recommended to print the patient name on the barcode label.

The barcode reader is detected by SpaceCom automatically. Via the service program HiBaSeD it is possible to set up the behavior of a pump in case a barcode reader is connected. Since SW U or higher of the pump the following settings are possible:

HiBaSeD menu Others:

- Activation of barcode reader menu within "Special functions"
- Show barcode reader menu during the Start-up of the pump

HiBaSeD menu Barcode:

Authorized nurse ID scan: The nurse is asked to scan a nurse ID. The nurse ID is stored in the history protocol of the pump and transferred via BCC protocol.

Patient ID matching: The user is asked to scan the patient ID. In this case the patient ID must be included in the medication container label as well and the pump checks if the patient ID (patient wrist band) matches to the ID coded on the medication container label.

Sharing nurse ID: The scanned nurse ID is shared with all other pumps within the system.

The duration of validity defines the time the information (Patient ID and Nurse ID) are valid within the pump. After this time the data needs to be scanned in again in case the barcode reader is used.

Look-up: The Look-up feature allows to link the information received via barcode with the drug library of a pump. In case the drug name and the concentration of a drug are in the drug data base of the pump the other information programmed within the drug data base are added to the barcode information. In this case for example the soft- and hard limit settings are active.

In case the Look-up feature is not used the information contained in the barcode are displayed only. In this case a hand symbol is shown in front of the drug name displayed at the pump.

For detailed information please refer the Barcode Interface Specification.

SERVICE

The Space® System is to be subjected to a Technical Safety Check with registration in the Medical Device Book every 24 months.

The Technical Safety Checks may only be performed by technicians trained by B. Braun or technical personnel from B. Braun Medical Inc.

Individual agreements take into account the specific conditions of every hospital.

If required a complete Service Manual can be made available. However, Service Manuals can only be supplied to facilities that have successfully completed B. Braun technical training.

Note: If the Space® System is to be integrated in existing wall or ceiling supply systems, please check whether this adaptation is permitted with the manufacturer of the supply systems.

The infusion pumps Infusomat® Space and the infusion syringe pump Perfusor® Space are to be submitted to a Technical Check with registration in the Medical Device Book according to the checklist every 2 years.

This 2-year maintenance should be carried out by B. Braun service personnel or technical staff trained by them.

The CE label confirms that this medical device corresponds to the "Directive of the Council for Medical Products 93/42/EC" of June 14, 1993.

MAINTENANCE / DISINFECTING / DISPOSAL / RECHARGEABLE BATTERIES

10.1 Maintenance

Operate the system only in accordance with the instructions for use.

Check, clean and disinfect the Space® System at regular intervals.

Check for cleanliness, completeness and damages.

Only use original spare parts and accessories.

Carry out the Technical Safety Check or maintenance of the Space® System with all additional units connected (e.g. PC) every 24 months.

10.2 Cleaning and Disinfecting

⚠ Attention: Before cleaning and disinfecting the SpaceStation, always disconnect from the patient, switch off the device and disconnect from power and other devices.

The SpaceStation may be cleaned and disinfected with EPA registered products containing the following agents:

- 1-propanol
- isopropyl alcohol
- ethanol
- didecyl dimethyl ammonium chloride
- diisobutylphenoxyethyl dimethyl benzyl ammonium chloride
- sodium hypochlorite

Note: Do not use alkylamine containing disinfectants.

Follow manufacturers' instructions for proper use of disinfecting products. Clean all external surfaces using a clean, soft, low lint cloth dampened with product or commercial wipes containing an approved agent. Make sure to remove any visible residue from all surfaces prior to disinfecting. Disinfect the housing of the SpaceStation with product containing an approved agent. Do not spray disinfectants directly on the SpaceStation, use a soft, low lint cloth dampened but not saturated with product or commercial wipes containing an approved agent. After cleaning and disinfecting, confirm the instrument is thoroughly dry before use.

Note: Keep instrument upright and do not allow any part of instrument to become saturated with or submersed in fluid during cleaning and disinfecting.

Do not allow moisture or disinfectants to come into contact with the electrical connections of the device or any device openings. To reduce the likelihood of moisture ingress into the electrical connectors, the F1A, F2A to F2D connector of a power supply may be used to cover the connections during cleaning and disinfecting.

Ensure that any connectors used to cover are not connected to a wall outlet or other electrical source. Once the cleaning has been completed, remove the connector and inspect all connectors for residual moisture and evidence of damage or breakdown to the plating on the connectors. Allow any residual moisture to evaporate before plugging the device into a wall outlet. Replace any connectors which exhibit damage or evidence of plating breakdown prior to returning the device to service. Utilize electrical contact cleaner that does not react with plastics to remove any deposits of material which may be present inside the electrical connectors as required.

⚠ Caution: Do not allow liquids to enter into or come into contact with any openings or electrical connections on the pump or power supply. Fluid exposure in these areas may result in the risk of short circuit, corrosion or breakdown of sensitive electrical components, and/or electrical shock. If fluid exposure occurs, the device should be swapped out with another device. The device should remain unplugged until it can be inspected by biomedical engineering for any evidence of damage and/or residual moisture which may impair the function of the device.

Note: The use of unapproved cleaners and failure to follow the disinfection procedures and the manufacturer's recommended dilutions can result in an instrument malfunction or product damage and could void the warranty.

10.3 Disposal











The SpaceStations as well as battery packs can be returned to B. Braun for disposal. Separate disposal is required for electrical and electronic equipment (2002/96/EC).



10.4 Rechargeable Batteries

- Charge the battery before initial start-up.
- The mean service life of the batteries is approximately 3 years.
- Time of recharging: typically 6 h (NiMH).
- In case of a power failure the system automatically switches over to the recharge-able battery (if existing).
- Charge and remove batteries out of the unit if the system is not used for a longer period of time (storage time > 2 weeks).
- If the batteries are stored for longer time, recharge at least once a year is recommended.
- The service life of the batteries can be prolonged if they are regularly completely discharged and recharged at the mains.
- Rechargeable batteries must be recycled (special refuse).

This table describes symbols in general but does not replace the technical specification of the described product.

Symbol	Explanation
	Mandatory action: see instructions for use
	Consult instructions for use
	Defibrillation-proof type CF applied part
	Class II equipment
	Symbol indicating separate collection for electrical and electronic equipment (2002/96/EC)
	Temperature Limit
	Humidity Limitation
	Limitation of the atmospheric pressure
	Non-ionizing electromagnetic radiation
	General warning sign (e.g. Caution)

List of abbreviations:

PDMS = Patient Data Management System

MRI = Magnetic Resonance Imaging

TECHNICAL DATA

11.1 B. Braun SpaceStation without B. Braun SpaceCom

Type of unit	System rack for connection of up to 4 infusion pumps
Classification (acc. to IEC/EN 60601-1)	☑ Defibrillator-proof; CF equipment Protective Class I
Class (acc. to Directive 93/42/ECE)	IIb
Protection class	IP 22 (drip protected)
Power supply	Primary: 100 ... 240V 50/60Hz 80VA 110V 0.46A / 220V 0.23A (mains fuse 2A slow blow) Secondary: 12V DC / 35W (cooling: convection) Duty cycle 100%
External low voltage supply	11 ... 16V DC --- (via Connection Lead SP 12)
Staff call	max. 24V / 1A /24VA (via Connection Lead for Staff Call) floating output Observe VDE0834 Pay attention to national requirements
Housing leakage current (incl. cabling)	one station six stations NC < 35 µA NC < 110 µA SFC < 70 µA SFC < 220 µA
Patient leakage current	< 1 µA
EMC	acc. to IEC EN 60601-1-2:2001 +A1:2006 and IEC EN 60601-2-24:1998
Operation in ambulance cars	acc. to 2009/19/EG(2004/104/EG)
Electronic with following functions	
Protection of pump connector	Release of power outlet only if pump is seated in Electronic fuse 12V/1.8A
Interface to SpaceCom	optional device
Protection of SpaceCover	Release of power outlet only if cover is mounted Electronic fuse 12V/1.5A
Configuration of SpaceStation	Dynamic configuration depending of the mounted SpaceStations
Addressing of pumps	Dynamic addressing related to the position of the pump within the system
Ports	
Power supply input	IEC socket for standard network cable

Outlet of mains voltage	Connector for power supply of the next SpaceStations
Pump connector	4 connectors (F2A..F2D) for Infusomat® or Perfusor® Space®
Connection between modules	Interconnection of several SpaceStation via plugs F3 and F4
Connection to periphery	Connection of accessories PCA button SP Connection lead for Staff Call Connecting Lead SP (12 V) Interface Lead SP via plug F3
Operating conditions	
Relative humidity	30% ... 90%, without condensation
Temperature	5°C (41°F) ... 40°C (104°F)
Atmospheric pressure	500mbar ... 1060mbar
Storage conditions	
Relative humidity	20% ... 90%, without condensation
Temperature	-20°C (-4°F) ... 55°C (131°F)
Atmospheric pressure	500mbar ... 1060mbar
Weight (w/o Cover , with pole clamp)	3.6 kg (7.9 lbs)
Dimensions W x H x D (without Cover)	290 x 327 x 160 mm (11.4 x 12.9 x 6.3 inch)
Dimensions W x H x D (with Cover)	290 x 364 x 160 mm (11.4 x 14.3 x 6.3 inch)

11.2 B. Braun SpaceStation with SpaceCom (since serial number 10.000)

Like B. Braun SpaceStation without B. Braun SpaceCom with the following modifications

Rated voltages	Primary: 100 ... 240V 50/60Hz 110V 0.6A / 220V 0.3A (mains fuse 2A slow blow) Secondary: 12V DC --- / 42W (with forced ventilation) turn-on duration 100%
Temperature controlled ventilator	Ventilator powers up at approximately 55°C (131°F) Internal temperature
Inserted SpaceCom	
Power consumption	At 12V 5-7.3W (depending on used accessories) without battery charge (approximately 3W battery charge)
Electrical isolation	External interfaces have an electrical isolation of 1.5kV to the SpaceStation

EMC	acc. to IEC 60601-1-2:2001+A1:2006 and IEC 60601-2-24:1998
Internal interfaces	Connection for battery pack Connection to electronics and interface to the pumps USB-Master (USB 2.0) for WLAN-interface
External Interfaces	2x (1x normal, 1x low-power (USB 2.0)) Ethernet for integration of network Serial interface
Optional battery, for power supply of SpaceCom at power failure/transport	
Type of battery	NiMH battery pack
Operating time of battery	approximately 1.5 hours
Charging time	approximately 6 hours

11.3 B. Braun SpaceStation with SpaceCom (up to serial number 9.999)

Like B. Braun SpaceStation without B. Braun SpaceCom with the following modifications

Rated voltages	Primary: 100 ... 240V 50/60Hz 110V 0,6A / 220V 0,3A (mains fuse 2A slow blow) Secondary: 12V DC / 42W (with forced ventilation) turn-on duration 100%
Temperature controlled ventilator	Ventilator powers up at 55°C (131°F) Internal temperature
Inserted SpaceCom	
Power consumption	At 12V 2,5 to 4W (depending on used accessories) without battery charge (approximately 3W battery charge)
Electrical isolation	External interfaces have an electrical isolation of 4kV to the SpaceStation
EMC	acc. to IEC EN 60601-1-2:1993 and IEC EN 60601-2-24:1998
Internal interfaces	Connection for battery pack Connection to electronics and interface to the pumps Compact Flash Slot for WLAN-interface
External Interfaces	USB-Master e.g. for memory sticks USB-Slave for connection of a PC Ethernet for integration of network PS2 Interface Serial interface

Optional battery, for power supply of SpaceCom at power failure/transport

Type of battery	NiMH battery pack
Operating time of battery	approximately 2 hours
Charging time	approximately 6 hours

11.4 B. Braun SpaceCover comfort

Pillar cover of the SpaceStation	Covers outlet of mains voltage of SpaceStation below Makes comfortable carrying of a SpaceStation possible For central alarm of a SpaceStation For power supply of a SpaceStation at power failure/transport
Inserted electronics	
Power consumption	At 12V approximately 1W without battery charge (approximately 3W battery charge)
Loud speaker	For central audible alarm for SpaceStation
LED indicator fields	For central optical display of status of SpaceStation
Display battery status for SpaceCom	Display Status of Battery of Space Station Display Status of Battery of SpaceCom Display Mode of Operation Battery-/Mains operation. Switch on/off of the SpaceStation in battery mode Display of failures Release battery maintenance
Internal Interfaces	Interface to battery Interface to display- and operating unit
External Interface	Interface to SpaceStation
Optional battery, for power supply of the SpaceStation at power failure/transport	
Type of battery pack	NiMH battery pack
Operating time of battery	approximately 1.5 hours with SpaceCom approximately 10 h without SpaceCom
Charging time	approximately 6 hours
Weight	0.9 kg (1.98 lbs)
Dimensions W x H x D	261 x 82 x 160 mm (10.3 x 3.2 x 6.3 inch)

Guidance and manufacturer's declaration on electromagnetic compatibility

Guidance and manufacturer's declaration – electromagnetic emission		
The Space® System is intended for use in the electromagnetic environment specified below. The customer or the user of the Space System or any component should assure that it is used in such an environment.		
Emissions test	Compliance	Electromagnetic environment – guidance
RF emissions CISPR 11	Group 1	The Space System uses RF energy only for its internal function. Therefore, its RF emissions are very low and are not likely to cause any interference in nearby electronic equipment. If WLAN-Module is installed within Battery module (8713182A) or WLAN USB Stick for SpaceCom (8713185) is used RF energy is transmitted by the Space System. Note: The optional WiFi module (2.4GHz / 100mW) can cause interference with devices in the vicinity. Please observe the necessary minimum distance requirements.
RF emissions CISPR 11	Class B ^{Note 2}	The Space System or any component is suitable for use in all establishments, including domestic establishments and those directly connected to the public low-voltage power supply network that supplies buildings used for domestic purposes.
Harmonic emissions IEC 61000-3-2	only applicable for SpaceStation Class A	
Voltage fluctuations / flicker emissions IEC 61000-3-3	Complies	
Note 1: Maximum emissions are measured with a complete system (SpaceStation and components).		
Note 2: If Class A equipment is attached to the Space System, the Space System will become Class A too. This equipment/system may cause radio interference or may disrupt the operation of nearby equipment. It may be necessary to take mitigation measures, such as re-orienting or relocating the Space System or shielding the location.		

Guidance and manufacturer's declaration – electromagnetic immunity			
The Space® System is intended for use in the electromagnetic environment specified below. The customer or the user of the Space System or any component should assure that it is used in such an environment.			
Immunity test	test level IEC 60601-1-2 IEC 60601-2-24	Compliance level	Electromagnetic environment – guidance
Electrostatic discharge (ESD) according IEC 61000-4-2	<u>contact</u> IEC 60601-1-2: ±6 KV IEC 60601-2-24: ±8 KV <u>air</u> IEC 60601-1-2: ±8 KV IEC 60601-2-24: ±15 KV	±6 KV no disturbances ±8 KV stop with alarm possible ±8 KV no disturbances ±15 KV stop with alarm possible	Floors should be wood, concrete or ceramic tile. If floors are covered with synthetic material, the relative humidity should be at least 30 %.
Electrostatic transient / burst according IEC 61000-4-4	± 2 KV for power supply lines ± 1 KV for input/output lines	±2 KV ±1 KV	Mains power quality should be that of a typical commercial or hospital environment.
Surge according IEC 61000-4-5	±1 KV differential mode ±2 KV common mode	±1 KV ±2 KV	Mains power quality should be that of a typical commercial or hospital environment.
Voltage dips, short interruptions and voltage variations on power supply input lines according IEC 61000-4-11	< 5 % U_T (>95 % dip in U_T) for 0,5 cycle 40 % U_T (60 % dip in U_T) for 5 cycles 70 % U_T (30 % dip in U_T) for 25 cycles < 5 % U_T (>95 % dip in U_T) for 5 sec <5% U_T for 5 s (>95% dip)	Complies by use of internal battery	Mains power quality should be that of a typical commercial or hospital environment. If the user of the Space System requires continued operation during long time A/C power interruptions, it is recommended that the Space System or component be powered from an uninterruptible power supply or a battery.
Power frequency (50/60 Hz) magnetic field according IEC 61000-4-8	3 A/m	400 A/m	Power frequency magnetic fields should be at levels characteristic of a typical location in a typical commercial or hospital environment.
Note: Different test values of IEC 60601-2-24 are marked in the table. At these test values no dangerous disturbances occurred at the lower test values of IEC 60601-1-2.			

Guidance and manufacturer's declaration – electromagnetic immunity			
The Space® System is intended for use in the electromagnetic environment specified below. The customer or the user of the Space System or any component should assure that it is used in such an environment.			
Immunity test	test level IEC 60601-1-2 IEC 60601-2-24	Compliance level	Electromagnetic environment – guidance
radiated electromagnetic RF fields according IEC 61000-4-6	IEC 60601-1-2: 3 V _{eff} normal and 10V _{eff} in ISM frequency band		Portable and mobile RF communications equipment should be used no closer to any part of the Space System or it's components, including cables, than the recommended separation distance calculated from the equation applicable to the frequency of the transmitter. Recommended separation distance d = 1.2 √P Field strengths should be less then 10V/m
radiated electromagnetic RF fields according IEC 61000-4-3	IEC 60601-2-24: 10 V _{eff} 150 KHz to 80 MHz 10 V/m 80 MHz to 2.5 GHz	10V _{eff} 150 KHz to 80 MHz 10 V/m 80 MHz to 3 GHz	d = 1.2 √P 80 MHz to 800 MHz d = 2.3 √P 800 MHz to 2.5 GHz where p is the maximum output power rating of the transmitter in watts (W) according to the transmitter manufacturer and d is the recommended separation distance in meters (m). Field strengths from fixed RF transmitters, as determined by an electromagnetic site survey, should be less than the compliance level in each frequency range. Interference may occur in the vicinity of equipment marked with the following symbol: 
NOTE 1: At 80 MHz and 800 MHz, the higher frequency range applies.			
NOTE 2: These guidelines may not apply in all situations. Electromagnetic propagation is affected by absorption and reflection from structures, objects and people.			
NOTE 3: Different test values of IEC 60601-2-24 are marked in the table. At these test values no dangerous disturbances occurred at the lower test values of IEC 60601-1-2.			

Recommended separation distances between portable and mobile RF communications equipment and the Space® System			
The Space® System is intended for use in an electromagnetic environment in which radiated RF disturbances are controlled. The customer or the user of the Space System or component can help prevent electromagnetic interference by maintaining a minimum distance between portable and mobile RF communications equipment (transmitters) and the Space System as recommended below, according to the maximum output power of the communications equipment			
rated power of the radio transmitter W	Separation distance according to frequency of transmitter m		
	150 kHz bis 80 MHz 1.2√P	80 MHz bis 800 MHz 1.2√P	800 MHz bis 2.5 GHz 2.3√P
0.01	0.12	0.12	0.23
0.1	0.38	0.38	0.73
1	1.2	1.2	2.3
10	3.8	3.8	7.27
100	12	12	23
<p>NOTE 1: For transmitters rated at a maximum power output not listed above, the recommended separation distance (d) in meters (m) can be determined using the equation applicable to the frequency of the transmitter, where (P) is the maximum output power rating of the transmitter in watts (W) according to the transmitter manufacturer.</p> <p>NOTE 2: An additional factor of 10/3 is used in calculating the recommended separation distance for transmitters in the frequency range 0.15 MHz to 2.5 GHz to decrease the likelihood that mobile/portable communications equipment could cause interference if it is inadvertently brought into patient areas.</p> <p>NOTE 3: These guidelines may not apply in all situations. Electromagnetic propagation is affected by absorption and reflection from structures, objects and people.</p>			

GNU GENERAL PUBLIC LICENSE

Version 2, June 1991

Copyright (C) 1989, 1991 Free Software Foundation, Inc.,
51 Franklin Street, Fifth Floor, Boston, MA 02110-1301 USA.
Everyone is permitted to copy and distribute verbatim copies
of this license document, but changing it is not allowed.

Preamble

The licenses for most software are designed to take away your freedom to share and change it. By contrast, the GNU General Public License is intended to guarantee your freedom to share and change free software—to make sure the software is free for all its users. This General Public License applies to most of the Free Software Foundation's software and to any other program whose authors commit to using it. (Some other Free Software Foundation software is covered by the GNU Lesser General Public License instead.) You can apply it to your programs, too.

When we speak of free software, we are referring to freedom, not price. Our General Public Licenses are designed to make sure that you have the freedom to distribute copies of free software (and charge for this service if you wish), that you receive source code or can get it if you want it, that you can change the software or use pieces of it in new free programs; and that you know you can do these things.

To protect your rights, we need to make restrictions that forbid anyone to deny you these rights or to ask you to surrender the rights. These restrictions translate to certain responsibilities for you if you distribute copies of the software, or if you modify it.

For example, if you distribute copies of such a program, whether gratis or for a fee, you must give the recipients all the rights that you have. You must make sure that they, too, receive or can get the source code. And you must show them these terms so they know their rights.

We protect your rights with two steps: (1) copyright the software, and (2) offer you this license which gives you legal permission to copy, distribute and/or modify the software.

Also, for each author's protection and ours, we want to make certain that everyone understands that there is no warranty for this free

software. If the software is modified by someone else and passed on, we want its recipients to know that what they have is not the original, so that any problems introduced by others will not reflect on the original authors' reputations.

Finally, any free program is threatened constantly by software patents. We wish to avoid the danger that redistributors of a free program will individually obtain patent licenses, in effect making the program proprietary. To prevent this, we have made it clear that any patent must be licensed for everyone's free use or not licensed at all.

The precise terms and conditions for copying, distribution and modification follow.

GNU GENERAL PUBLIC LICENSE TERMS AND CONDITIONS FOR COPYING, DISTRIBUTION AND MODIFICATION

0. This License applies to any program or other work which contains a notice placed by the copyright holder saying it may be distributed under the terms of this General Public License. The "Program", below, refers to any such program or work, and a "work based on the Program" means either the Program or any derivative work under copyright law: that is to say, a work containing the Program or a portion of it, either verbatim or with modifications and/or translated into another language. (Hereinafter, translation is included without limitation in the term "modification".) Each licensee is addressed as "you".

Activities other than copying, distribution and modification are not covered by this License; they are outside its scope. The act of running the Program is not restricted, and the output from the Program is covered only if its contents constitute a work based on the Program (independent of having been made by running the Program). Whether that is true depends on what the Program does.

1. You may copy and distribute verbatim copies of the Program's source code as you receive it, in any medium, provided that you conspicuously and appropriately publish on each copy an appropriate copyright notice and disclaimer of warranty; keep intact all the notices that refer to this License and to the absence of any warranty; and give any other recipients of the Program a copy of this License along with the Program.

You may charge a fee for the physical act of transferring a copy, and you may at your option offer warranty protection in exchange for a fee.

2. You may modify your copy or copies of the Program or any portion of it, thus forming a work based on the Program, and copy and distribute such modifications or work under the terms of Section 1 above, provided that you also meet all of these conditions:
 - a) You must cause the modified files to carry prominent notices stating that you changed the files and the date of any change.
 - b) You must cause any work that you distribute or publish, that in whole or in part contains or is derived from the Program or any part thereof, to be licensed as a whole at no charge to all third parties under the terms of this License.
 - c) If the modified program normally reads commands interactively when run, you must cause it, when started running for such interactive use in the most ordinary way, to print or display an announcement including an appropriate copyright notice and a notice that there is no warranty (or else, saying that you provide a warranty) and that users may redistribute the program under these conditions, and telling the user how to view a copy of this License. (Exception: if the Program itself is interactive but does not normally print such an announcement, your work based on the Program is not required to print an announcement.)

These requirements apply to the modified work as a whole. If identifiable sections of that work are not derived from the Program, and can be reasonably considered independent and separate works in themselves, then this License, and its terms, do not apply to those sections when you distribute them as separate works. But when you distribute the same sections as part of a whole which is a work based on the Program, the distribution of the whole must be on the terms of this License, whose permissions for other licensees extend to the entire whole, and thus to each and every part regardless of who wrote it.

Thus, it is not the intent of this section to claim rights or contest your rights to work written entirely by you; rather, the intent is to exercise the right to control the distribution of derivative or collective works based on the Program.

In addition, mere aggregation of another work not based on the Program with the Program (or with a work based on the Program) on a volume of a storage or distribution medium does not bring the other work under the scope of this License.

3. You may copy and distribute the Program (or a work based on it, under Section 2) in object code or executable form under the terms of Sections 1 and 2 above provided that you also do one of the following:
 - a) Accompany it with the complete corresponding machine-readable source code, which must be distributed under the terms of Sections 1 and 2 above on a medium customarily used for software interchange;
or,
 - b) Accompany it with a written offer, valid for at least three years, to give any third party, for a charge no more than your cost of physically performing source distribution, a complete machine-readable copy of the corresponding source code, to be distributed under the terms of Sections 1 and 2 above on a medium customarily used for software interchange;
or,
 - c) Accompany it with the information you received as to the offer to distribute corresponding source code. (This alternative is allowed only for noncommercial distribution and only if you received the program in object code or executable form with such an offer, in accord with Subsection b above.)

The source code for a work means the preferred form of the work for making modifications to it. For an executable work, complete source code means all the source code for all modules it contains, plus any associated interface definition files, plus the scripts used to control compilation and installation of the executable. However, as a special exception, the source code distributed need not include anything that is normally distributed (in either source or binary form) with the major components (compiler, kernel, and so on) of the operating system on which the executable runs, unless that component itself accompanies the executable.

If distribution of executable or object code is made by offering access to copy from a designated place, then offering equivalent access to copy the source code from the same place counts as distribution of the source code, even though third parties are not compelled to copy the source along with the object code.

4. You may not copy, modify, sublicense, or distribute the Program except as expressly provided under this License. Any attempt otherwise to copy, modify, sublicense or distribute the Program is void, and will automatically terminate your rights under this License. However, parties who have received copies, or rights, from you under this License will not have their licenses terminated so long as such parties remain in full compliance.

5. You are not required to accept this License, since you have not signed it. However, nothing else grants you permission to modify or distribute the Program or its derivative works. These actions are prohibited by law if you do not accept this License. Therefore, by modifying or distributing the Program (or any work based on the Program), you indicate your acceptance of this License to do so, and all its terms and conditions for copying, distributing or modifying the Program or works based on it.
6. Each time you redistribute the Program (or any work based on the Program), the recipient automatically receives a license from the original licensor to copy, distribute or modify the Program subject to these terms and conditions. You may not impose any further restrictions on the recipients' exercise of the rights granted herein. You are not responsible for enforcing compliance by third parties to this License.
7. If, as a consequence of a court judgment or allegation of patent infringement or for any other reason (not limited to patent issues), conditions are imposed on you (whether by court order, agreement or otherwise) that contradict the conditions of this License, they do not excuse you from the conditions of this License. If you cannot distribute so as to satisfy simultaneously your obligations under this License and any other pertinent obligations, then as a consequence you may not distribute the Program at all. For example, if a patent license would not permit royalty-free redistribution of the Program by all those who receive copies directly or indirectly through you, then the only way you could satisfy both it and this License would be to refrain entirely from distribution of the Program.

If any portion of this section is held invalid or unenforceable under any particular circumstance, the balance of the section is intended to apply and the section as a whole is intended to apply in other circumstances.

It is not the purpose of this section to induce you to infringe any patents or other property right claims or to contest validity of any such claims; this section has the sole purpose of protecting the integrity of the free software distribution system, which is implemented by public license practices. Many people have made generous contributions to the wide range of software distributed through that system in reliance on consistent application of that system; it is up to the author/donor to decide if he or she is willing to distribute software through any other system and a licensee cannot impose that choice.

This section is intended to make thoroughly clear what is believed to be a consequence of the rest of this License.

8. If the distribution and/or use of the Program is restricted in certain countries either by patents or by copyrighted interfaces, the original copyright holder who places the Program under this License may add an explicit geographical distribution limitation excluding those countries, so that distribution is permitted only in or among countries not thus excluded. In such case, this License incorporates the limitation as if written in the body of this License.
9. The Free Software Foundation may publish revised and/or new versions of the General Public License from time to time. Such new versions will be similar in spirit to the present version, but may differ in detail to address new problems or concerns.

Each version is given a distinguishing version number. If the Program specifies a version number of this License which applies to it and "any later version", you have the option of following the terms and conditions either of that version or of any later version published by the Free Software Foundation. If the Program does not specify a version number of this License, you may choose any version ever published by the Free Software Foundation.

10. If you wish to incorporate parts of the Program into other free programs whose distribution conditions are different, write to the author to ask for permission. For software which is copyrighted by the Free Software Foundation, write to the Free Software Foundation; we sometimes make exceptions for this. Our decision will be guided by the two goals of preserving the free status of all derivatives of our free software and of promoting the sharing and reuse of software generally.

12. IN NO EVENT UNLESS REQUIRED BY APPLICABLE LAW OR AGREED TO IN WRITING WILL ANY COPYRIGHT HOLDER, OR ANY OTHER PARTY WHO MAY MODIFY AND/OR REDISTRIBUTE THE PROGRAM AS PERMITTED ABOVE, BE LIABLE TO YOU FOR DAMAGES, INCLUDING ANY GENERAL, SPECIAL, INCIDENTAL OR CONSEQUENTIAL DAMAGES ARISING OUT OF THE USE OR INABILITY TO USE THE PROGRAM (INCLUDING BUT NOT LIMITED TO LOSS OF DATA OR DATA BEING RENDERED INACCURATE OR LOSSES SUSTAINED BY YOU OR THIRD PARTIES OR A FAILURE OF THE PROGRAM TO OPERATE WITH ANY OTHER PROGRAMS), EVEN IF SUCH HOLDER OR OTHER PARTY HAS BEEN ADVISED OF THE POSSIBILITY OF SUCH DAMAGES.

END OF TERMS AND CONDITIONS

B. Braun Perfusor® Space® (100 – 240 V) + Battery-Pack SP with Wifi (Li-Ion)	8713031U
B. Braun Perfusor® Space® (100 – 240 V) + Battery-Pack SP without Wifi (NiMH)	8713032U
B. Braun SpaceStation.....	8713140U
B. Braun SpaceStation with SpaceCom	8713142U
B. Braun Perfusor® Space®	8713030U
B. Braun Infusomat® Space® (100 – 240 V) + Battery-Pack SP with Wifi (Li-Ion)	8713051U
B. Braun Infusomat® Space® (100 – 240 V) + Battery-Pack SP without Wifi (NiMH)	8713052U
B. Braun SpaceCom.....	8713160U
B. Braun SpaceCover Comfort.....	8713145U

Recommended accessories for B. Braun SpaceStation:

Space® IV Pole	N7537
Battery-Pack SP without Wifi (NiMH).....	8713180A
Extension lead SP 60 cm (23.62 inches).....	8713210
Extension lead SP 120 cm (47.24 inches).....	8713215
Extension lead SP 10 m (393.7 inches).....	8713315
Extension lead SP 15 m (590.5 inches).....	8713415
Connection Lead for Staff Call SP.....	8713232

Recommended accessories for B. Braun SpaceStation with SpaceCom
(up to serial number 9.999):

Battery-Pack SP without Wifi (NiMH).....	8713180A
RS232 cross over cable SP.....	8713237
RS232 connector converter SP.....	8713238

Recommended accessories for B. Braun SpaceStation with SpaceCom
(since serial number 10.000):

Battery-Pack SP without Wifi (NiMH).....	8713180A
RS232 cross over cable SP.....	8713237
RS232 connector converter SP.....	8713238
WLAN USB-STICK B/G/N.....	8713185U

Mozilla and Firefox are trademarks of the Mozilla Foundation in the U.S. and other countries.
Internet Explorer is a trademark of the Microsoft group of companies.
Java is a registered trademark of Oracle and/or its affiliates.
Other names may be trademarks of their respective owners.



Manufactured by
B. Braun Melsungen AG
34209 Melsungen
Germany

Tel +49 (0) 56 61 71-0

Distributed by

B. Braun Medical Inc.
824 12th Avenue
Bethlehem, PA 18018-3524 USA

38910176 • Drawing No. I0590701901
1023

Clinical and technical support for USA:
1-800-854-6851