

Infusomat® Space

and Accessories



Rx only

Instructions for Use

US Valid for software 686G

B | BRAUN

CONTENTS

Infusomat® Space Overview.....	3
Symbols on Product.....	5
Patient Safety.....	6
Menu Structure / Overview.....	9
Menu Structure / Navigation.....	10
Chapter 1 Operation.....	12
1.1 Start of Infusion.....	12
1.2 Entry With Different Combinations of Rate, VTBI (= Volume To Be Infused) and Time.....	14
1.3 Bolus Application.....	15
1.4 Infusion Line Change and New Therapy Start.....	16
1.5 End of Infusion.....	16
1.6 Standby Mode.....	17
Chapter 2 Advanced Operations.....	18
2.1 Status Request of Pump when Infusion is Running.....	18
2.2 Rate, VTBI and Time Change Without Infusion Interruption and Reset of Status Menu Data.....	18
Chapter 3 Special Functions*.....	19
3.1 Dose Rate Calculation (Overview).....	19
3.2 Dose Rate Calculation (Operation).....	19
3.3 Drug Library.....	20
3.4 Piggyback Function.....	21
Chapter 4 Options.....	23
4.1 Downstream Occlusion Pressure.....	23
4.2 Data Lock.....	23
4.3 Bolus Rate.....	24
4.4 KVO-Mode.....	24
4.5 Contrast / Display Light / Keypad Light.....	25
4.6 Alarm Volume.....	25
4.7 Date / Time.....	25
4.8 Macro Mode.....	25
4.9 Upstream Occlusion Pressure.....	25
Chapter 5 Alarms.....	27
5.1 Device Alarms.....	27
5.2 Pre-Alarms and Operating Alarms.....	27
5.3 Reminder Alarms.....	29
5.4 Alarm Hints.....	30
Chapter 6 Battery Operation and Maintenance.....	31
Chapter 7 Start Up Graphs and Trumpet Curves.....	33
Chapter 8 Technical Data.....	34
Chapter 9 TSC** / Service / Training / Disinfecting / Disposal.....	41
Chapter 10 Instructions for Use Accessory.....	45
Ordering.....	49
Technical Support.....	50

*The availability of the listed features is dependent upon the configuration settings of the pump.

**Technical Safety Check

INFUSOMAT® SPACE OVERVIEW



Follow on screen prompts using arrow keys to navigate menus, select parameters, change values and respond to on screen prompts.

Press to clear values in programming screens or to go back one screen.

Press to open the pump door.



Yellow LED: Pre-alarm, reminder alarm

Green or Red LED:  or 
 Green LED: Infusing
 Red LED: Operating or Device Alarm

Blue LED:  Initiating connection to SpaceStation



Press to initiate bolus.

Press to turn pump on/off and initiate stand by mode.

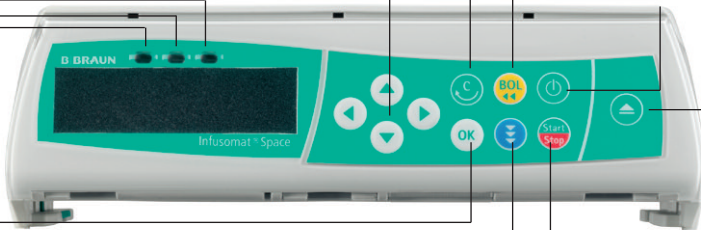

Press to select and/or confirm values / settings / alarms / messages.



not applicable



Press to Start/Stop infusion.

Cover of Battery Compartment

Before changing the battery, always disconnect the pump from the patient and switch off the device. To remove the battery cover push the button below the battery compartment with a pointed pen and pull the cover away from device. Slide green locking mechanism on back of battery up and take out battery pack for exchange. In case of emergency, a crank is attached to the inside of the battery compartment to open the pump door (for more information see 1.4).



Port for drop sensor
(not in US or Can)

Port P3 for future options

Port P2 for power supply, SpaceStation, connection lead (12V), combi lead and further accessory leads (staff call, service)

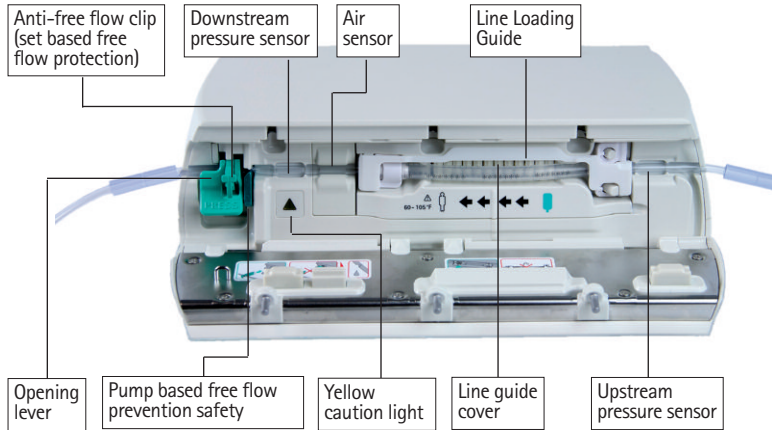

Pole Clamp SP (model 8713130)

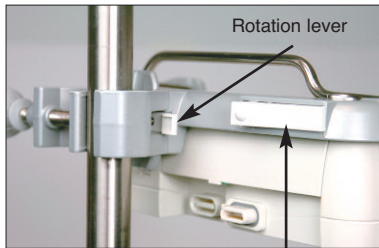















Pole clamp release button

Attaching Pole Clamp to IV Pole
 Position the opening of the Pole Clamp on pole and turn the grey locking knob clockwise until pole clamp is secured to IV pole. Turn grey knob counter clockwise to release. For vertical positioning of Pole Clamp push rotation lever down and rotate pump either way until lever clicks into notch. Push lever for rotation.

Caution: Do not lean on pump when attached to pole!

Caution: A maximum of three B. Braun Space pumps can be stacked together when used with the PoleClamp SP.

SYMBOLS ON PRODUCT

Symbol	Explanation
	Mandatory action: see instruction for use.
	See accompanying documents.
	Type CF unit with defibrillation protection
	Protection class II device
	Symbol indicating separate collection for electrical and electronic equipment (Directive 2012/19/EU).
	Temperature Limit
	Moisture Limit
	Limitation of the atmospheric pressure
	Non-ionizing electromagnetic radiation
	General warning sign (e.g. Caution)
	Unsafe symbol (Do not use in MRI environment!)
	MR conditional when used in SpaceStation MRI
	Batch number
	Serial number
	Medical device





Read Instructions for Use prior to operation. The infusion device should only be used by trained healthcare professionals.

PATIENT SAFETY

Intended use

The Infusomat® Space Volumetric Infusion Pump System is an electrical, external, volumetric infusion pump system indicated for use with adults, pediatrics and neonates and is intended to provide infusions of parenteral fluids/medications, blood and blood products indicated for infusion through FDA approved routes of administration.

Operation

- The initial training of the Infusomat® Space is to be performed by B. Braun sales personnel or other authorized persons. After each software update, the user is required to inform themselves about the changes to the device and accessories in the instructions for use.
- 
Caution: Ensure the unit is properly positioned and secured. Do not position pump unit above patient or in a position where a patient could come to harm, should the pump fall.
- Prior to administration, visibly inspect the pump for damage, missing parts or contamination and check audible and visible alarms during selftest.
- Qualified medical staff should decide how the device should be used based on its features and specifications. For more details, please read the Instructions for Use.
- Despite careful packaging, the risk of damage during transport cannot be entirely prevented. Upon delivery, please check that all items are present. Do not use a damaged device. Contact the service department. Testing the proper function of the device should be performed before initial use.
- Only connect to patient once the line has been correctly inserted and completely primed. Interrupt connection during line change to prevent incorrect dose delivery.
- Select infusion line/catheter suitable for use with the intended medical application.
- 
Caution: Position the infusion line free of kinks.
- Replace infusion lines/sets per CDC guidelines and/or institutional protocols.
- 
Caution: Do not operate the pump in the presence of flammable anaesthetics to prevent explosion.
- Compare the displayed value with the entered value. Only start the infusion if the values showing are the same.
- If staff call is used we recommend checking the equipment once after connecting the pump.

- Protect the device and the power supply against moisture.
- If the pump is dropped or is exposed to force, it must be checked by the service department.



Warning: The Infusomat Space Infusion Pump is unsafe when used as a standalone device in proximity to magnetic resonance imaging (MRI) equipment. The pumps, when within the SpaceStation MRI, can be used conditionally in the MR environment when complying to the SpaceStation MRI Instructions for Use. Do not remove the pump from the SpaceStation MRI in proximity to MRI equipment.

- The displayed data must always be checked by the user prior to making further medical decisions.
- Make sure the device is securely fixed and positioned. Positioning changes and severe shock can lead to minor changes in the delivery accuracy.
- A supplemental patient monitoring must be carried out if life-saving medication is performed.
- The air detector cannot detect air diffusing in the following components: three-way stopcocks, infusion adapters and downstream line/set between pump and patient.
- In case a critical drug is administered, it is recommended to have a second infusion pump available for the administered drug.
- Independent of the soft limits, the selected values have to be appropriate for the given patient.
- In case values for the dose rate calculation are changed, the flow rate will be updated and the dose rate will be fixed.
- In case the demand button is used with SpaceStation the PCA pump has to be placed in the lowest slot of the lowest SpaceStation.
- Any serious incident that has occurred in relation to this product should be reported to B.Braun and the competent authority (or equivalent country specific authority) of the country in which the product is operated.

Other components

- Use tubing manufactured by B. Braun exclusively for use with Infusomat® Space.
- Where several infusion lines are connected on one single vascular access, the possibility of the lines exerting a mutual influence over each other cannot be excluded.
- Refer to respective pharmaceutical manufacturer's package insert (PI) for any possible medication incompatibilities.

- Use only compatible combinations of equipment, accessories, working parts and disposables with luer lock connectors.
- Connected electrical equipment must comply with the relevant IEC/EN-specifications (e.g. IEC/EN 60950 for data-processing equipment). The user/operator is responsible for the system configuration if additional equipment is connected. The international standard IEC/EN 60601-1-1 has to be taken into account.









Safety Standards

Infusomat® Space satisfies all safety standards for medical electrical devices in compliance with IEC 60601-1:2005 and IEC 60601-2-24: 2012.

- The EMC-limits (electro-magnetic compatibility) according to IEC 60601-1-2:2007 and IEC 60601-2-24: 2012 are maintained. If the equipment is operated in the vicinity of other equipment which may cause high levels of interference (e.g. HF surgical equipment, nuclear spin tomography units, mobile telephones etc.) may be disturbed. Maintain the protective distances recommended by the manufacturers of these devices.
- During use the Infusomat® Space needs to be fixed on a suitable restraint system by means of SpaceStation or Pole Clamp SP. When stored under temperature conditions beyond the defined operating conditions the Infusomat® Space needs to remain under room temperature at least one hour before usage.
- PCA is currently not marketed for Infusomat Space in the U.S.

MENU STRUCTURE / OVERVIEW

Cutline

-  On/Off button
 -  Door open button
 -  Start/Stop button
 -  Bolus button
-  Clear button
 -  OK button
 -  Keypad with arrow up, down, left, right button
 -  Connection button

Menu Structure

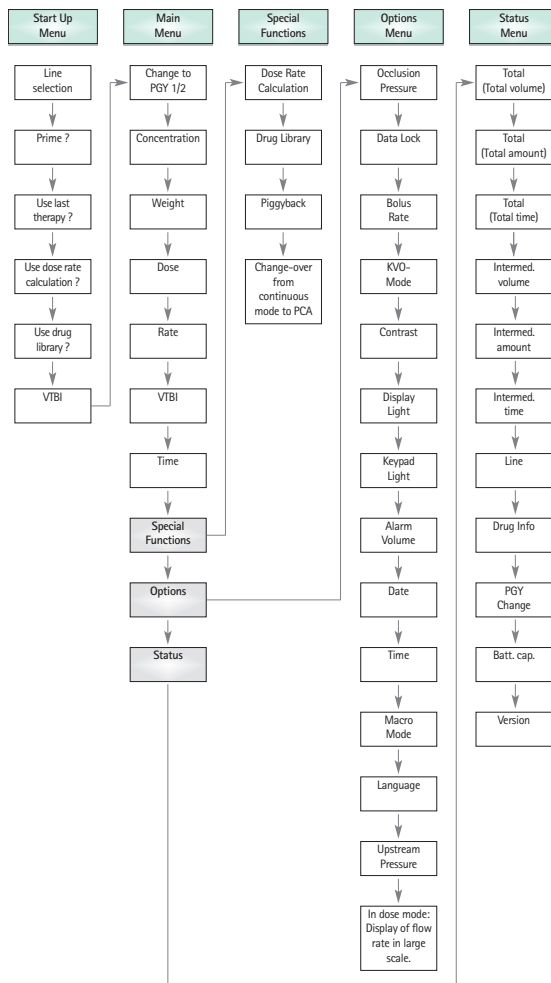

Menu items will vary dependent upon configuration settings. The pump can be customized by activating/deactivating the menu items of the Start Up (except VTBI) and Options Menu as well as the bolus function via the service program.

MENU STRUCTURE / NAVIGATION

Display

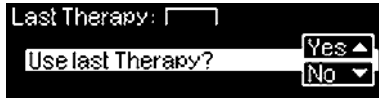

Explanation

At the top of the screen the last therapy is indicated. Yes/No question can be answered by pressing for yes or for no.

Parameters which can be changed (e.g. rate in mL/h) are opened with or . When editing parameters, switch digits/levels using . White background indicates current digit/level. Use or to change current setting. Help text on the bottom/top of the screen indicates options how to proceed (e.g. confirm rate with , start infusion with or clear rate by pressing).

Typical display during infusion:

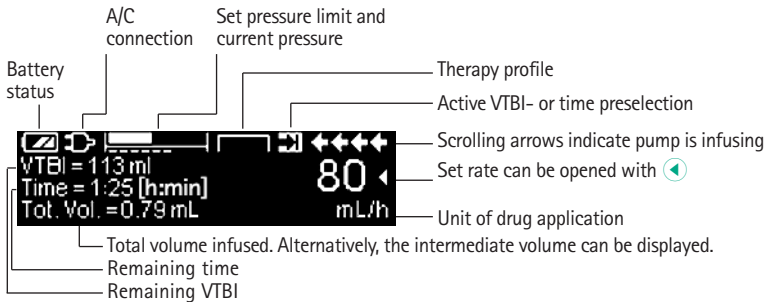

All status information is available in the bottom line of the display. The desired information can be selected by using and will be displayed permanently thereafter (e.g. drug long name, time/VTBI remaining).

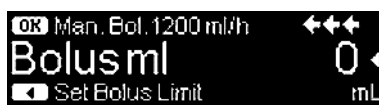

has been pressed while the pump is infusing. Start manual bolus at 1200 mL/h by pressing (see top of display) or proceed to set bolus limit with (see bottom of display).

Display

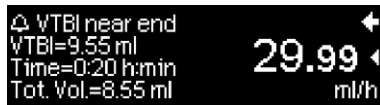

Explanation

This phrase pops up if a user tries to edit or change a parameter by pressing when that parameter is unable to be changed.

Set pressure level with or and confirm by pressing .
Cancel to edit pressure by using .



Pre-alarms are indicated by a message on the display (e.g. "VTBI near end"), an audible tone and a flashing yellow LED. To confirm a pre-alarm press .

In case of an operating alarm (e.g. "VTBI infused") the infusion stops, an audible tone sounds and the red LED flashes. Confirm alarm by using .
Confirming does not activate an acoustic feedback.

Press and hold for 3 sec to turn pump off. A white bar stretches from left to right and counts down the 3 sec. As long there is an infusion line inserted the pump will not turn off but will enter standby mode.

OPERATION

1.1 Start of Infusion

- Ensure that the pump is properly secured. Check the equipment for completeness and damage. Do not attach the infusion bag/bottle below the pump level.
- Put the spike vertically into the infusion bag/bottle. Fill the bottom part of the drop chamber maximum two thirds.
- Fill the infusion line then close the roller clamp.
- If the device is connected to the A/C power supply, the display indicates the battery status, A/C power symbol and the last given therapy.
- Press  to switch on the device. Observe the automatic self-test: The message "Self-test active" and the software version are displayed. Two audible tones sound and all three LEDs (yellow, green/red and blue) flash once. Information about the power source (A/C or battery) and the current pressure level are indicated. The line type appears initially, provided that the set is already inserted. Next, the accumulated air volume and maximum bubble size is indicated, which are triggers for the pump's accumulative air and single air bubble alarms.
- Press  and  to open the pump door in order to insert the line.

Caution: You may only insert the line while the device is switched on and the line guide element is inserted. Otherwise, there is the danger of freeflow. Pay attention to keep the roller clamp closed before inserting the infusion line. . Never leave the pump unattended when inserting the line/set.



Insert the IV line from right to the left starting with the 2 hole clip.



Next attach the white clip. Insure silicone segment is not stretched or twisted, stars on tubing must be in straight line and line loading guide should not be twisted.

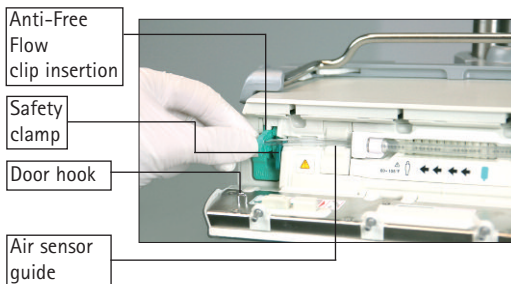
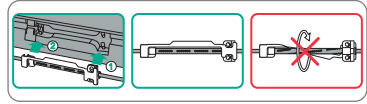

Insert the green anti-freeflow clip in the green slot, in the direction indicated by the arrow, until the opening lever snaps out, yellow light goes out and pump based free flow protection safety clamp occludes the lines.

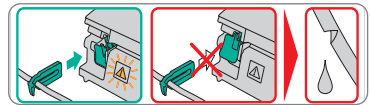

- Close the pump door and select the inserted line with then confirm it with . Open the roller clamp.
 - Caution:** Do not force door closed - If door is difficult to close, please check IV set and anti free-flow slide clamp (green) for proper installation.
 - Caution:** If a wrong line is selected, errors may occur during therapy and alarms may be affected.
 - Caution:** When opening door, please ensure door does not fall open. If door opens to the horizontal position, please check that the slide clamp (green) is properly occluding the IV set and the door extension hook is not broken. If the door hook is found damaged or broken remove the pump from service.
- Press to prime the infusion line with the displayed rate (if enabled). Cancel priming with . Repeat the procedure until the line is completely primed. Then press to proceed.



Note: During priming, the air alarm is switched off.



- Establish the patient connection.
- Answer the question whether to use the previous therapy (Yes or No) either with or (this question can be deactivated via the service program). If you select , the pump's Main Menu is displayed. If you select , you must first enter a VTBI which is smaller than the container volume, and confirm it with .

Note: At rates smaller than 1 mL/h, the detection of a closed roller clamp cannot always be sensed due to physical reasons. Therefore it is recommended, especially at

small rates, to verify that there is no occlusion in the infusion line and that falling drops can be viewed in the set's drip chamber.

Adjusting the delivery rate:

- In the Main Menu, select rate with  and set it with .
- Press  to start the infusion. Running arrows are visible on the display and the green LED indicates that the infusion was started.









Note: An infusion can be stopped at any time by pressing . The pump can be placed into standby mode at any time by pressing  for 3 sec (Exception: Data lock level 2), as long as a set is installed.

1.2 Entry With Different Combinations of Rate, VTBI (= Volume To Be Infused) and Time

The Infusomat® Space offers the possibility to enter a volume or time limit in addition to an infusion rate. When two of these parameters are entered, the third is calculated by the pump. If volume or time is preselected, an arrow symbol is placed in front of the selected parameter in the Main Menu. It is called the "target". During the infusion, this target symbol is displayed next to the moving arrows in the run display. This indicates that the pump has been programmed, either with a volume or time limit. The assignment of the target symbol, apparent in the Main Menu, shows the established parameter for the application (VTBI or time). When the rate is changed, the so-called target parameter is maintained and only the third parameter is recalculated. After the infusion has started, the remaining VTBI and time are displayed in the Main Menu and the run display (values will be counting down).

1.) Enter VTBI and time: The infusion rate will be calculated and displayed on the bottom of the display.

Target: Volume

- Select VTBI with  and open with .
- Enter VTBI with  and confirm with .
- Select time with  and open with .
- Enter time with  and confirm with .

Check calculated rate value is correct.

Proceed in the same way to calculate 2.) and 3.).

2.) Infusion with volume limit

Enter rate and VTBI: The infusion time will be calculated and displayed on the bottom of the display.

Target: VTBI

3.) Infusion with time limit

Enter rate and time: The infusion volume will be calculated and displayed on the bottom of the display.

Target: Time

Changing entered values of VTBI and time (Hint - rate, VTBI and time are already calculated and populated prior to change):

a) Target symbol in front of VTBI:













- Change of VTBI => Adjust time. Previous and new target remains as VTBI
- Change of time => Adjust rate. Previous and new target remains as VTBI

b) Target symbol in front of time:



- Change of time => Adjust VTBI. Previous and new target remains Time
- Change of VTBI => Adjust time. New target is now VTBI

1.3 Bolus Application

There are three ways to administer a bolus:

- 1.) Manual Bolus: Press . Then press and hold . Fluid is administered for as long as the button is held down. The infused bolus volume is displayed. The maximum bolus time is limited to 10 seconds. Reaching this limit is indicated by an audible signal and a discontinued bolus.
- 2.) Bolus with volume preselection: Press . Then press  and set bolus dose limit by using . Press  to confirm and start the bolus. Depending on the pump configuration, an audible signal will sound after the bolus volume has been administered.
- 3.) Bolus with rate calculation: Press . Then press  and set bolus dose by using . Press  to confirm bolus dose. Set the time with  in which a bolus is to be delivered. The calculated bolus rate is displayed on top. Press  to confirm and start the bolus.



The unit of the bolus always depends on the selected dose. For example if the dose selected is mg/kg/hr, then the bolus will be given in mg/kg. If a dose is administered without a relation to the patient's weight (mg/hr), then the bolus will be given in mg.

After pressing the button  the bolus unit can be selected by using . The selected unit will be stored and offered as default. This enables the user to administer a bolus in mL. This is available in dose calculation mode.

You can use the service program to enter a default and maximum bolus rate. Once a new therapy is started, the device always returns to the default rate, even if the bolus rate was manually changed beforehand.

Note: If the bolus limit is not entered after pressing , the display reverts back into the run display automatically.



Note: During volume preselection, the infused bolus volume counts up.

To flush the line, ensure the pump is stopped and patient is disconnected. Press  and answer the following question by pressing  to start the flush. Cancel by pressing  or any other key.





Caution: Be sure not to overdose! Given a bolus rate of 1200 mL/h, 1 mL will be administered in 3 sec. To cancel bolus infusion at any time press . At low bolus volumes, under dosages due to the start up characteristic of the pump, the tolerances in the infusion system cannot be excluded. Disconnect patient while priming.

1.4 Infusion Line Change and New Therapy Start

Note: To avoid dosing errors, always disconnect the patient line before changing the disposable. Never let the pump run unattended when changing the line. Check and clean the safety clamp regularly.





- Press  to stop the delivery. The green LED goes out. Close the set's roller clamp and disconnect the patient connection.
- Press  and open the pump door with . Press down the pump's green safety clamp completely until it locks in place. Remove the line and insert a new line.

Note: If the pump door cannot be opened, use the crank located inside the battery compartment cover. Use this crank to remove the access port on the side of the pump. Place the crank in the access port. Turn it clockwise (as indicated) until the pump door opens.

- Close the pump door. Confirm the inserted line with  and open the roller clamp.
- If required, prime the pump with . Then press  to proceed.
- Establish the patient connection and check the parameters with .
- Start the infusion by pressing .

Note: A new therapy can be started at any time the pump is not infusing. If the pump is in the Main, Status or Options Menu, press  repeatedly, following the instructions as described.









1.5 End of Infusion

- Press  to stop an infusion. The green LED goes out. Close the set's roller clamp and disconnect the patient.
- Press  and respond whether the pump door is to be opened with .
- Press down on the pump's green safety clamp completely until it locks in place. Remove the line and close the pump door.
- Press  for 3 sec to power off the pump.

Note: The settings will be saved when the device is switched off.





1.6 Standby Mode



In the case of extended interruption, the user has the option to maintain the set values.

- Press  to stop the infusion. Then press  for less than 3 sec.
 - Confirm that the pump switches to standby by pressing .
 - The default time for standby is displayed. Accept the default time with  or change it with  (0-24 hours) and then confirm by pressing .
- => While the pump is in the standby mode, its display shows the drug and the remaining time for this mode. Change remaining time by pressing . Exit standby by pressing .





ADVANCED OPERATIONS

2.1 Status Request of Pump when Infusion is Running

Press  to switch between run display and Main Menu while the pump is running. Navigate through the menu using  to check parameters. In order to check the menu parameters, in the Status or Options Menu, select "Status", "Options" from the Main Menu. Access menu with  and scroll through menu with .





Status information is also available as a default on the display (e.g. drug long name, time or VTBI remaining) To select, as the pump runs, press either cursor button  or . Scroll and choose desired information. Desired information will remain as the default setting.



2.2 Rate, VTBI and Time Change Without Infusion Interruption and Reset Of Status Menu Data

- Press  when the pump is in the run display in order to switch to the Main Menu. Select rate/VTBI/time with  and press  in order to access the parameter.
- Enter new value with  and confirm with .

Reset Status Menu Data:

Parameters such as intermediate volume and time can be reset when the pump is infusing or when the pump has stopped.

- Select "Status" in Main Menu with  and press .
- Highlight intermediate volume (in mL) or intermediate time (in h:min) with  and open parameter with .
- Reset values by pressing .

Both parameters, total volume and time, are displayed in the pump as "Total" with their respective unit, and can be reset by starting a new therapy. A second way to reset the parameters is while the pump is in the Main Menu. Press , answer the question whether the last therapy is to be used with , and reset the values with .

The IV line is displayed upon installation into the pump. The menu item "Line" must be confirmed once prior to programming an initial infusion. The drug info states the drug name, the name of the drug list and its date of origin. The option to change from secondary to primary infusion either manually or automatically will be displayed in line "PGY change". The current battery capacity in hours and minutes is displayed in the menu item "Battery Capacity" and the current software version in menu item "Version".

SPECIAL FUNCTIONS

3.1 Dose Rate Calculation (Overview)















The dose rate calculation enables a calculation of the rate in mL/h from the entered dose parameters.

$$\text{Infusion rate [mL/h]} = \frac{\text{Dose}}{\text{Concentration}} \times [\text{Patient weight (optional)}]$$

Setting parameters:



1. Concentration is the amount of the drug (active ingredient) per volume.
 - Amount of the active ingredient in µg, mg, mmol, IU or mEq.
 - Volume in mL.
2. Where necessary: Patient weight in kg or lbs.
3. Dose prescription:
 - time related as the amount of the drug (active ingredient) per min, hour or 24 hours
 - time and patient weight related as the amount of the drug (active ingredient) per kg per min, h or 24h.
4. Where necessary: VTBI in mL.

3.2 Dose Rate Calculation (Operation)

- Select dose rate calculation with .
- Select the unit of the drug (active ingredient) with  and confirm it with .
- Enter the concentration by entering the amount of the drug (active ingredient) and the volume. In order to do so set the values with  and confirm with .
- If the patient's weight does not need to be entered press . Press  for a time and weight related calculation, set the patient weight with  and confirm it with .
- Select the dose unit with  and confirm it with .
- Set the dose with  and confirm with . The rate will be automatically calculated and displayed at the bottom of the display.
- Check with  if the calculated rate and if necessary the adapted parameters on the screen are correct before starting the infusion with .

Concentration and dose can later be changed in the Main Menu in the same way as the rate, VTBI and time (refer to section 2.2). Changes to weight and dose interfere with other parameters. The effect of those changes are shown at the bottom of the display.

Additionally the total and intermediate amount of the infused drug can be removed from the Status Menu. These can be checked and reset in the same way as the other total and intermediate values.

Exiting from the dose rate calculation is only possible when the pump is stopped. Press  from Main Menu and then press .

Caution: A change of the patient weight will alter the flow rate.

3.3 Drug Library







Up to 720 drug names including therapy data and information can be stored in a maximum of 15 categories. The loading process into the pump can be performed using a separate PC program ("Drug List Editor Space").

Note: The drug library can be started from the Start Up and Special Functions Menu. The user has to make sure prior to the therapy start that the drug library in the pump complies with the patient target group or area of application. The name of the drug library (see headline) will be displayed on the pump.

There are different ways of activating the drug library. This can be done while the infusion is running or when the pump is stopped.

A drug name, including its relevant therapy data, can be taken from the drug library. If a rate, VTBI and/or time, were already defined in the Main Menu, the drug name and the adjusted values of the data set will be loaded. If a dose rate calculation has already been started, a belated assignment of the drug name is possible.

To activate drug name and related parameters:







- Open the drug library by pressing .
- Navigate through list with  and select the category with .
- Select the drug from the category with .
- Confirm the displayed drug information with .
- Check if the drug short name in the Main Menu is the same as the selected drug. Check the parameter in the Main Menu with  and start infusion with .

Hard Limits:

If the set rate/dose/bolus volume and bolus rate exceed the values stored in the drug library (hard limits), the drug will be rejected, "Dose Guard values have reached upper limit" will be displayed, and the pump will fall back into the drug selection. If this occurs while the pump is infusing, the pump will continue the infusion.

Soft Limits:

For the same parameters, so called soft limits can be preset via the Drug List Editor. These limits can be exceeded if the user so chooses. The following symbols describe the status with regard to the soft limits being displayed:

The infusion is within the range of the minimum and maximum soft limits	=	
The infusion is within the range of the maximum soft limit	=	
The infusion is within the range of the minimum soft limit	=	
Violation of the upper soft limit	=	
Violation of the lower soft limit	=	
No soft limit is defined	=	
Only a drug name is available (It is possible to select a drug name only from the drug library)	=	

The limits of the drug library have to comply with the limits of the pump and the disposable.

Note: Insure close patient monitoring when infusing critical drugs.

Note: In case a drug from the drug library is selected and the pump is running under dose rate calculation, the initial values will be overwritten by the drug library values when selected.

3.4 Piggyback Function





The piggyback mode offers the possibility to interrupt the current (primary) infusion temporarily in order to administer a piggyback (secondary) infusion. Above the pump the piggyback-infusion line is connected with a Y-connector to the administration set. The secondary infusion should be located approximately 8 inches higher than the primary infusion. All infusion lines need to be completely primed. A backcheck valve must be attached according to the drawing (see next page).

A precondition to start the piggyback function is that the pump has been stopped.

Note: Set a VTBI of the primary and secondary infusion that corresponds to the size of the container.

- Enter the rate manually or program the pump via the dose rate calculation or the drug library. It is not possible to begin with the secondary infusion if the data for the primary infusion (rate and VTBI) is not set.
- Select "Piggyback" from the Special Functions Menu and confirm with .

Chapter 3

- The change from the secondary to the primary infusion ("PIGY" to "PRIM") can be done manually or automatically. When prompted, choose automatic change or manual by answering the question with  or .
- The rate and VTBI of the secondary infusion can be programmed via the dose rate calculation, drug library, or manually with .
- Start secondary infusion by pressing . Device delivers the piggyback volume with the set piggyback rate.



Symbols in the headline of the run display ("PRIM" or "PIGY") will indicate if the primary or secondary infusion is currently running.

When the piggyback delivery is completed, the pump automatically changes to the primary infusion, if this was selected. If the VTBI of the primary infusion has infused, the pump will continue in KVO at the respective rate. After KVO, the pump stops and an alarm is activated. If a manual change from the secondary infusion to primary infusion was selected, the pump will stop or continue with KVO after the secondary infusion has completed. The user must manually change via the menu item "Change to PRIM" in the Main Menu to the primary infusion and start with .

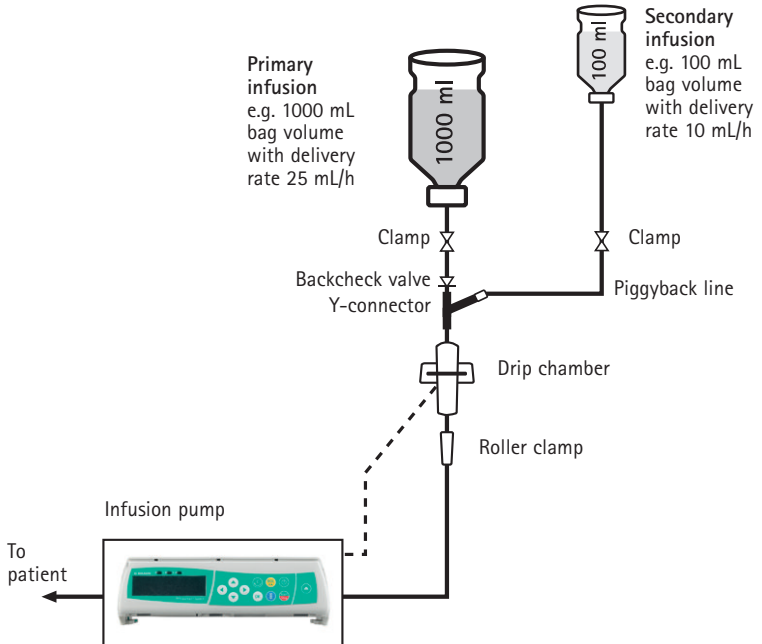
Note: Switching manually between primary and secondary infusion in the Main Menu is possible at any time while the pump is stopped. It is recommended to keep the roller clamp of the non-active infusion closed.







OPTIONS

The options function may be selected and changed while the pump is infusing or stopped. To edit a menu item, select "Options" in the Main Menu and press . Then select desired function with  and follow the Instructions for Use as described.

4.1 Downstream Occlusion Pressure

The higher the pressure setting, the higher the pressure level must rise before triggering a downstream occlusion alarm.

- Enter pressure in the Options Menu by pressing .
- Choose between nine pressure levels (1=lowest level; 9=highest level) by pressing  or  and confirm entry with .

4.2 Data Lock

The data lock function protects the device against unauthorized access. A four digit code (default setting "9119"), which can be changed via the service program activates this function in level 1 or level 2. There are two security levels.

Level 1:

A modification of values as well as a bolus application are not possible but a change of the disposable can be conducted. It is possible to navigate through all menus and status data can be checked. The pump can also be started, stopped and shut down.







Level 2:

This level has the same performance characteristic as described under level 1 , but will not allow you to change the disposable. In order to prevent a data lock alarm the correct code must be entered within 20 seconds after the pump was stopped. Only after entering the correct code can the disposable be changed and the pump turned off.



Event	Level 1	Level 2
Change of disposable	✓	✗
Start of infusion	✓	✗
Change of parameters	✗	✗
Stop of infusion	✓	✓ 
Switching off pump / Standby	✓	✗
Customizable screen	✗	✗
Acoustic feedback of demanded boli	✗	✗
Indicates denied PCA boli	✓	✓

✓ = possible | ✗ = not possible |  = followed by standby-alarm



Activation of the function:

- Open data lock in Options Menu with .
- Select between level 1 and 2 (if activated) with  and  and confirm with .
- Enter code with  and press  in order to activate data lock.

Changes to the protected values and the bolus function which are marked with  are only possible after entering the code. After 20 seconds in the Main Menu, Status Menu, Special Functions Menu and Options Menu the lock will be activated again. If the wrong code is entered twice the pump will switch into the last menu. If the wrong code is entered twice again the pump will go into an audible alarm, a staff call will go off and the yellow LED blinks. If a target value was reached while data lock is active a new start of the pump is only possible after entering the code.

In order to deactivate the function, select "Off" in the data lock, press , enter the code and press  again.



4.3 Bolus Rate

- Access bolus rate in Options Menu with .
- Change bolus rate with  and confirm setting with .

Note: Set bolus rate according to therapy requirements. Be sure not to overdose! Given high bolus rates (e.g. 1200 mL/hr), 0.33 mL are reached within just one second.





4.4 KVO-Mode

The pump can continue the infusion with a preset KVO-rate after a preselected VTBI/time has passed (see "Technical Data"). The duration of the KVO delivery is selected in the service program.

- Access the KVO-mode in the Options Menu with .
- Answer the Yes/No question with  to enable the KVO-mode.





4.5 Contrast / Display Light / Keypad Light

Contrast as well as display and keypad light can be adjusted individually according to the lighting conditions.

- Access contrast/display light/keypad light in Options Menu by pressing .
- Choose between 9 contrast- and display light levels with  or  and confirm with .

4.6 Alarm Volume

Chose between 9 different alarm volume levels.



- Access alarm volume in Options Menu with .
- Set volume with  or  and confirm entry with .

4.7 Date / Time

- Access date/time in the Options Menu with .
- Modify date and time with  and confirm the setting with .

4.8 Macro Mode

The infusion rate appears larger on the display when the macro mode is activated and the pump is infusing.

- Open macro mode in Options Menu with .
- Answer Yes/No question by pressing  to activate the macro mode.

For quick activation of macro mode: Press and hold  while the pump is infusing until the font size changes.

4.9 Upstream Occlusion Pressure





The device is equipped with an upstream pressure sensor that detects an occlusion (e.g. closed roller clamp, kinked line) between the container and the pump. The higher the pressure level is set, the lower the pressure level must drop before triggering an upstream occlusion pressure alarm.

Chapter 4

- Access upstream pressure in Options Menu by pressing ◀.
- Choose between nine pressure levels (1=lowest level; 9=highest level) by pressing ◀ or ▶ and confirm entry with OK.

ALARMS

The Infusomat® Space is equipped with audible and optical alarm signals.

Alarm-type	Audible signal	Optical signal			Staff call	User confirmation
		Red LED	Yellow LED	Text		
Device Alarm	yes	flashes	flashes	device alarm and alarm code (see service program)	yes	Press  and follow the instruction on the display.
Operating-Alarm	yes	flashes	off	see alarm description	yes	Press  to acknowledge the audible alarm, alarm text and staff call.
Pre-Alarm	yes	off	flashes	see alarm description	(de-)activate via service program	Press  to mute alarm and turn off staff call. Visible alarm remains until end.
Reminder Alarm	yes	off	flashes	see alarm description	yes	Press  to mute alarm, turn off staff call and delete the alarm text.
Alarm Hint	no	off	off	see alarm description	no	Hint disappears without confirmation.

5.1 Device Alarms

When a device alarm occurs the infusion is immediately stopped. Press  to switch off the device. Then switch the device on again. In case of a repeated device alarm, you must close the roller clamp, disconnect from the patient, open the front door of the pump and take out the disposable. The device needs to be sent to the service department.

5.2 Pre-Alarms and Operating Alarms

Pre-alarms:

Pre-alarms occur a few minutes (depending upon service settings) prior to operating alarms. During pre-alarms an audible tone sounds, the yellow LED blinks and a staff call is activated (optional). The display message varies depending on the alarm reason. The signal tone and the staff call are turned off with . Display and LED stay in pre-alarm mode until the operating alarm goes off. Pre-alarms do not stop the infusion.

Display message	Pre-alarm reason
"VTBI near end"	The preselected volume is nearly infused.
"Time near end"	The preselected time is almost over.
"Battery nearly empty"	The battery is almost discharged.
"KVO active"	VTBI/time are reached and the pump continues the infusion at the KVO-rate.
"Communication error"	The pump is located in a system in which at least one device is incompatible or defective. The use of this device in a system is not permitted. The system is to be checked by a service technician.

A stopwatch on the display counts down the remaining time (depending on the service program, between 3-30 minutes). After that, the pump changes to the operating alarm.

The pre-alarms "VTBI near end" (volume preselection) and "Time near end" (time preselection) can be deactivated via the service program.

Operating alarms:

Operating alarms lead to an interruption of the infusion. An audible tone sounds, the red LED flashes and a staff call is activated. The display states "Alarm" and the reason for the operating alarm. The signal tone and the staff call are turned off with . Corrections are to be made according to the alarm source.

Display message	Alarm reason
"VTBI infused "	The preselected volume was infused. Continue therapy or select new therapy.
"Time expired"	The preselected time has ended. Continue therapy or select new therapy.
"Battery empty"	The battery pack is discharged. Connect device with A/C power and/or exchange battery pack. The battery alarm will be on for 3 minutes. Then the pump will automatically turn off.
"Pressure high"	An occlusion occurred in the system. The set pressure level was exceeded. A bolus reduction is automatically initiated by the pump. Check if tubing contains kinks or is damaged as well as IV- and filter patency. Increase occlusion pressure if necessary.
"KVO finished"	The KVO-time has ended. Continue therapy or set new therapy.

"Battery cover removed"	The battery cover is not properly engaged on the battery compartment. When pushing on the battery cover listen for a "click".
"Standby time expired"	The set standby time has ended. Set new time or continue with previously set therapy.
"No battery inserted"	It is not possible to use the pump without a battery pack. Turn off pump and insert battery pack according to description "Overview Infusomat® Space".
"Drive blocked"	Stepper motor does not deliver due to excess pressure in the system. Disconnect the patient and reinsert the line.
"Calibrate device"	Pump calibration data have changed (e.g. after an update). Recalibrate device via the service program.
"Air bubble "/"Accumulated air"	Air inside the system. Check the line/set for small air bubbles and disconnect from patient to repeat priming, if necessary.
"Therapy data were reset"	Therapy data could not be restored. Enter therapy again.
"Data Lock"	An attempt was made to stop or switch the pump off without entering the appropriate code. Enter the correct code in order to continue the therapy respectively turning the pump off.

The red LED doesn't extinguish until the displayed message is acknowledged or the pump is turned off.

Caution: If a wrench is displayed and/or a yellow, red and blue LED blink then the pump is in the service mode and is not permitted to be used on a patient. The pump must then be checked by a service technician.

5.3 Reminder Alarms

Reminder alarms only occur in two cases due to inactivity:

1. A line is inserted, the pump does not deliver, no value is edited and the device is not operated for two minutes.
An acoustic tone sounds, the yellow LED blinks and a staff call is activated.
 - a) The display states "Reminder alarm!"
 - b) The display states "Config. not finished!"

Confirm alarm with  and continue to set therapy/Start Up configuration.

2. A data / program entry was started but not finished and confirmed. This may also occur in the case of a missing disposable.

An acoustic tone sounds, the display states "Value not accepted", the yellow LED blinks and a staff call is activated.

Confirm alarm with  and continue to set therapy.

5.4 Alarm Help

In case of incorrect entries, the display will show relevant instructions (e.g. Caution: rate is out of range or "The parameter cannot be changed") and an audible tone sounds. These warnings disappear after a few seconds and don't need to be confirmed.

BARCODING

Please contact your local B. Braun sales representative for barcoding information.

BATTERY OPERATION AND MAINTENANCE

The Infusomat® Space is equipped with the latest NiMH-battery. It has an operating lifetime of 4 hours at 100 mL/h when new. For battery life, the device is equipped with protection against overcharge and deep depletion. The battery pack is charged by the pump during connection to A/C power. When disconnected from A/C or in case of power failure, the pump automatically switches to battery power.

Note: Prior to a prolonged storage of the pump (> half a months) the battery pack should be completely charged and then removed from the pump. Before changing the battery always disconnect the pump from the patient and switch off the device.

The battery status indicator is a trend display (low, medium, high). For more detailed information on the current battery capacity (operating time in hours and minutes) please refer to menu item "Battery Capacity" in the Status Menu of the Infusomat® Space.

Important information for battery self-check:

If the battery symbol is blinking during A/C power operation, the battery is either discharged or has a reduced capacity. In this case, the pump should not be disconnected from A/C. If it is necessary to disconnect the pump from A/C power for urgent reasons, the user should check to ensure if the battery capacity is sufficient for the proposed use. When the battery symbol blinks permanently (>1h), the battery must be checked by a technician and replaced if necessary.

Directions for optimal battery use:

The actual battery life may vary due to

- ambient temperature
- varying load (e.g. frequent boluses).



The optimal life time of a battery pack will only be reached if it's completely discharged from time to time. A maintenance mode which conducts this battery maintenance is built into the device. This function should be activated once a month. Furthermore:

- If possible, only charge the battery if it has been completely discharged.
- Under normal temperature conditions a battery can be charged and discharged approximately 500 times before its lifetime decreases.
- When the pump is not connected to A/C power, the battery discharges itself slowly. This can occur even when the pump is not operating. The original capacity will only be reached after several cycles of charging and discharging.
- The battery operating time only can be realized if the pump operates continuously with a fully charged battery at room temperature. The display of the battery operating time on the pump is an approximate value based on the current delivery rate. If the battery is aged it may differ from the actual achievable operating time.

Caution: Batteries may explode or leak if they are opened or incinerated. Therefore, please follow your institutions disposal regulations.

Battery maintenance:

To accurately balance the battery capacity a cyclical battery maintenance is necessary. The pump asks the user to perform a battery maintenance every 30 days. The battery maintenance mode detects a possible capacity loss (e.g. through aging of the battery pack) and rebalances the capacity/duration time. After a longer storage time or a longer operation without battery maintenance it can happen that the battery pre-alarm time can no longer be maintained. In this case it is necessary to perform a battery maintenance.

To initiate the discharge process the message "Battery maintenance" and the  key will be displayed after switching the pump off. By pressing  and , the discharge process is initiated. If the pump is turned on again the process will be interrupted. To continue battery maintenance, the pump has to be reactivated. After complete discharge, the battery must be completely recharged. The entire battery maintenance procedure takes about 12 hours.

Caution: If the battery maintenance has not been completed there is a possibility of a reduced battery operating time.

START UP GRAPHS AND TRUMPET CURVES

Start Up Graphs

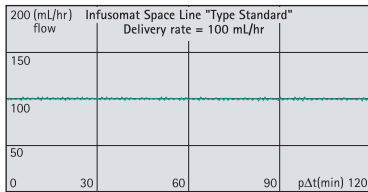
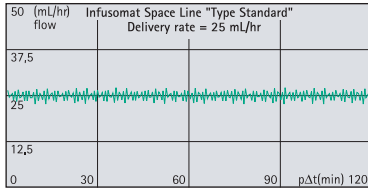
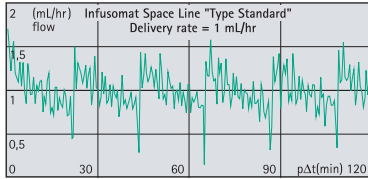

Trumpet Curves

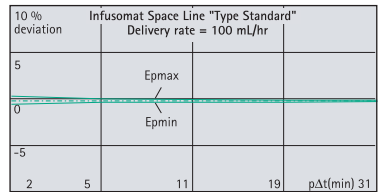
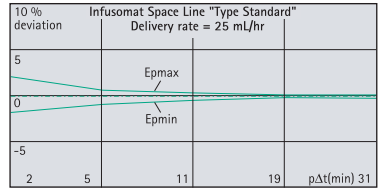
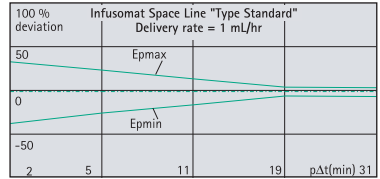

The graphs above show the accuracy/uniformity of flow in relation to time.
Note: The delivery characteristics may be influenced by the disposable used.
 Deviations from the technical data of the pump cannot be excluded if lines or disposables, other than those stated, are used.

Trumpet Curves

Measured values for second hour in each case.

Measurement interval $\Delta t = 0.5 \text{ min}$

Observation interval $p \times \Delta t \text{ [min]}$

Start Up Graphs

Measurement interval $\Delta t = 0.5 \text{ min}$

Measurement duration $T = 120 \text{ min}$

Flow $Q_i \text{ (mL/h)}$

TECHNICAL DATA

Type of unit	Volumetric infusion pump
Classification (acc. to IEC/EN 60601-1)	<input checked="" type="checkbox"/> defibrillator-proof; CF equipment <input type="checkbox"/> Protective Class II; Protective Class I in combination with SpaceStation
Class (acc. to Directive 93/42 EEC)	IIb
Moisture protection	IP 22 (drip protected for horizontal usage)
External power supply:	
■ Rated voltage	Via B. Braun SpaceStation or optional A/C adaptor (rated voltage 100 ... 240 V AC~, 50/60 Hz) for stand alone operation
■ External low voltage	11 ... 16 V DC --- via Connection Lead SP 12 V or via SpaceStation
Staff call	Max. 24 V / 0,5 A / 24 VA (VDE 0834)
EMC	IEC/EN 60601-1-2 / 60601-2-24
Time of operation	100 % (continuous operation)
Operating conditions:	
■ Relative humidity	30 % ... 90 % (without condensation)
■ Temperature	+60 ... + 105° F
■ Atmospheric pressure	500 ... 1060 mbar
Storage conditions:	
■ Relative humidity	20 % ... 90 % (without condensation)
■ Temperature	-4...+131° F
■ Atmospheric pressure	500 ... 1060 mbar
Type of battery pack (rechargeable)	NiMH
Operating time of rechargeable battery	Approx. 4 hours at 100 mL/h
Recharging time	Approx. 6 hours
Weight	Approx. 1.4 kg = Approx 3.08 lbs
Dimensions (W x H x D)	214 x 68 x 124 mm = 8.4 x 2.6 x 4.8 inches
Volume preselection	0.1 - 99.99 mL in increments of 0.01 mL 100 - 999 mL in increments 0.1 mL 1000 - 9999 mL in increments 1 mL
Time preselection	00:01 - 99:59 h
Accuracy of set delivery rate	± 5 % according to IEC/EN 60601-2-24
Administration Set Change Interval	Pumping accuracy is maintained for a minimum of 96 hours.
Max. Volume in case of single fault condition	For incorrect dosages of 1.4 mL due to malfunctions of the device the pump will automatically shut off

Technical inspection (safety check)	Every 2 years																																						
Rate increments	0.1 - 99.99 mL/h in increments of 0.01 mL/h 100 - 999.9 mL/h in increments of 0.1 mL/h 1000 - 1200 mL/h in increments of 1 mL/h																																						
Multiple lines connected to one patient port	Connecting multiple infusion lines with different flow rates may affect the rate for all infusions past the point of connection.																																						
Accuracy of bolus infusion	typ. \pm 5 % as of a bolus volume > 1 mL																																						
KVO-rate	Delivery rate \geq 10 mL/h: KVO-rate 3 mL/h Delivery rate < 10 mL/h: KVO-rate 1 mL/h Delivery rate < 1 mL/h: KVO-rate = set rate (default setting 0.1 mL/h)																																						
Computer connection	USB connection in combination with B. Braun interface lead CAN SP (8713230) including electrical insulation. Please pay attention to safety notices.																																						
Air detector	Technical sensitivity: Detection of air bubbles \geq 0.01 mL Alarm triggers: At an air bubble size of 0.02 - 0.3 mL* and 1.5 mL/h** (cumulated value over 1 h from air bubbles size 0.01 mL).																																						
Sensitivity upstream sensor	9 levels from -90 mmHg to -160 mmHg (pressure reduction)																																						
Occlusion alarm pressures	9 levels from 225 mmHg to 900 mmHg																																						
<table border="1"> <thead> <tr> <th rowspan="2"></th> <th colspan="4">Occlusion pressure</th> <th rowspan="2">Max. bolus [mL]</th> </tr> <tr> <th>[bar]</th> <th colspan="3">Time to occlusion alarm [min] at rate</th> </tr> <tr> <th></th> <th></th> <th>[1 mL/h]</th> <th>[25 mL/h]</th> <th>[100 mL/h]</th> <th></th> </tr> </thead> <tbody> <tr> <td>Level 1</td> <td>typ. 225</td> <td>09:07</td> <td>00:33</td> <td>00:07</td> <td>0.0347</td> </tr> <tr> <td>Level 5</td> <td>typ. 563</td> <td>25:53</td> <td>01:14</td> <td>00:15</td> <td>0.0987</td> </tr> <tr> <td>Level 9</td> <td>typ. 900</td> <td>46:50</td> <td>02:06</td> <td>00:24</td> <td>0.1787</td> </tr> </tbody> </table>							Occlusion pressure				Max. bolus [mL]	[bar]	Time to occlusion alarm [min] at rate					[1 mL/h]	[25 mL/h]	[100 mL/h]		Level 1	typ. 225	09:07	00:33	00:07	0.0347	Level 5	typ. 563	25:53	01:14	00:15	0.0987	Level 9	typ. 900	46:50	02:06	00:24	0.1787
	Occlusion pressure				Max. bolus [mL]																																		
	[bar]	Time to occlusion alarm [min] at rate																																					
		[1 mL/h]	[25 mL/h]	[100 mL/h]																																			
Level 1	typ. 225	09:07	00:33	00:07	0.0347																																		
Level 5	typ. 563	25:53	01:14	00:15	0.0987																																		
Level 9	typ. 900	46:50	02:06	00:24	0.1787																																		
Mechanical occlusion pressure limit under fault conditions	Occlusion alarm pressure max. 1575 mmHg (210 kPa). Max. bolus volume 2 mL.																																						
Alarm volume	9 levels from 1 (59dBA) to 9 (74dBA)																																						

History protocol

Logs are accessed via the service program.

Pump logs include history log of 1000 past entires, alarm log, key stroke and notes log. Refer to HiBaSed IFU for more information.

* to be set via the service program in increments of 0.01 mL

** to be set via the service program from 0.5–3.8 mL/h in increments of 0.1 mL

EMC (ELECTROMAGNETIC COMPATIBILITY)

Guidance and manufacturer's declaration on electromagnetic compatibility

Guidance and manufacturer's declaration – electromagnetic emission		
The Space System is intended for use in the electromagnetic environment specified below. The customer or the user of the Space System or any component should assure that it is used in such an environment.		
Emissions test	Compliance	Electromagnetic environment guidance
RF emissions CISPR 11	Group 1	The Space System uses RF energy only for its internal function. Therefore, its RF emissions are very low and are not likely to cause any interference in nearby electronic equipment. If WLAN-Module is installed within Battery module (8713182A) or WLAN USB Stick for SpaceCom (8713185) is used RF energy is transmitted by the Space System. Refer to technical data of Battery-Pack SP with Wifi IUF and/or SpaceStation and SpaceCom for details.
RF emissions CISPR 11	Class B ^(Note 2)	The Space System or any component is suitable for use in all establishments, including domestic establishments and those directly connected to the public low-voltage power supply network that supplies buildings used for domestic purposes.
Harmonic emissions IEC 61000-3-2	applicable only for SpaceStation Class A	
Voltage fluctuations / flicker emissions IEC 61000-3-3	Complies	
<p>Note 1: Maximum emissions are measured with a complete system (SpaceStation and components).</p> <p>Note 2: If Class A equipment is attached to the Space System, the Space System will become Class A too. This equipment/system may cause radio interference or may disrupt the operation of nearby equipment. It may be necessary to take mitigation measures, such as re-orienting or relocating the Space System or shielding the location.</p>		

Guidance and manufacturer's declaration – electromagnetic immunity			
The Space System is intended for use in the electromagnetic environment specified below. The customer or the user of the Space System or any component should assure that it is used in such an environment.			
Immunity test	test level IEC 60601-1-2 IEC 60601-2-24	Compliance level	Electromagnetic environment – guidance
Electrostatic discharge (ESD) according IEC 60601-4-2	<u>contact</u> IEC 60601-1-2: ±6KV IEC 60601-2-24: ±8KV <u>air</u> IEC 60601-1-2: ±8KV IEC 60601-2-24: ±15KV	±6KV no disturbances ±8KV stop with alarm possible ±8KV no disturbances ±15KV stop with alarm possible	Floors should be wood, concrete or ceramic tile. If floors are covered with synthetic material, the relative humidity should be at least 30 %.
Electrostatic transient / burst according IEC 61000-4-4	± 2 kV for power supply lines ± 1 kV for input/output lines	±2KV ±1KV	A/C power quality should be that of a typical commercial or hospital environment.
Surge according IEC 61000-4-5	differential mode ±1KV common mode ±2KV	±1KV ±2KV	A/C power quality should be that of a typical commercial or hospital environment.
Voltage dips, short interruptions and voltage variations on power supply input lines according IEC 61000-4-11	< 5 % UT (>95 % dip in UT) for 0,5 cycle 40 % UT (60 % dip in UT) for 5 cycles 70 % UT (30 % dip in UT) for 25 cycles < 5 % UT (>95 % dip in UT) for 5 sec <5% UT for 5 s (>95% dip)	complies by use of internal battery	A/C power quality should be that of a typical commercial or hospital environment. If the user of the Space System requires continued operation during long time A/C power interruptions, it is recommended that the Space System or component be powered from an uninterruptible power supply or a battery.
Power frequency (50/60 Hz) magnetic field according IEC 61000-4-8	3 A/m	400 A/m	Power frequency magnetic fields should be at levels characteristic of a typical location in a typical commercial or hospital environment.
Note: Different test values of IEC 60601-2-24 are marked in the table. At the test values no dangerous disturbances occurred at the lower test values of IEC 60601-1-2.			

Guidance and manufacturer's declaration – electromagnetic immunity			
The Space System is intended for use in the electromagnetic environment specified below. The customer or the user of the Space System or any component should assure that it is used in such an environment.			
Immunity test	test level IEC 60601-1-2 IEC 60601-2-24	Compliance level	Electromagnetic environment – guidance
<p>conducted electromagnetic RF fields according IEC 61000-4-6</p> <p>radiated electromagnetic RF fields according IEC 61000-4-3</p>	<p>IEC 60601-1-2: 3 Veff normal and 10Veff in ISM frequency band</p> <p>IEC 60601-2-24: 10 Veff 150KHz to 80MHz</p> <p>10 V/m 80 MHz to 2,5 GHz</p>	<p>10Veff 150KHz to 80MHz</p> <p>10 V/m 80 MHz to 3 GHz</p>	<p>Portable and mobile RF communications equipment should be used no closer to any part of the Space System or it's components, including cables, than the recommended separation distance calculated from the equation applicable to the frequency of the transmitter.</p> <p>Recommended separation distance</p> <p>$d = 1,2 \sqrt{P}$ Field strengths should be less then 10V/m</p> <p>$d = 1,2 \sqrt{P}$ 80 MHz to 800 MHz</p> <p>$d = 2,3 \sqrt{P}$ 800 MHz to 2,5GHz</p> <p>where p is the maximum output power rating of the transmitter in watts (W) according to the transmit-ter manufacturer and d is the rec-ommended separation distance in meters (m).</p> <p>Field strengths from fixed RF transmitters, as determined by an electromagnetic site survey, should be less than the compliance level in each frequency range.</p> <p>Interference may occur in the vicinity of equipment marked with the following symbol:</p> 
<p>NOTE 1: At 80 MHz and 800 MHz, the higher frequency range applies.</p> <p>NOTE 2: These guidelines may not apply in all situations. Electromagnetic propagation is affected by absorption and reflection from structures, objects and people.</p> <p>NOTE 3: See next page.</p>			

NOTE 3: Different test values of IEC 60601-2-24 are marked in the table. At these test values no dangerous disturbances are allowed while at the lower test values of IEC 60601-1-2. Field strengths from fixed transmitters, such as base stations for radio (cellular/cordless) telephones and land mobile radios, amateur radio, AM and FM radio broadcast and TV broadcast cannot be predicted theoretically with accuracy. To assess the electromagnetic environment due to fixed RF transmitters, an electromagnetic site survey should be considered. If the measured field strength in the location in which the Space System is used exceeds the applicable RF compliance level above, the Space System should be observed to verify normal operation. If abnormal performance is observed, additional measures may be necessary, such as re-orienting or relocating the Space System.

The Space System is intended for use in an electromagnetic environment in which radiated RF disturbances are controlled. The customer or the user of the Space System or component can help prevent electromagnetic interference by maintaining a minimum distance between portable and mobile RF communications equipment (transmitters) and the Space System as recommended below, according to the maximum output power of the communications equipment.

rated power of the radio transmitter W	Separation distance according to frequency of transmitter m		
	150 kHz bis 80 MHz 1,2√P	80 MHz bis 800 MHz 1,2√P	800 MHz bis 2,5 GHz 2,3√P
0,01	0,12	0,12	0,23
0,1	0,38	0,38	0,73
1	1,2	1,2	2,3
10	3,8	3,8	7,27
100	12	12	23

NOTE 1: For transmitters rated at a maximum power output not listed above, the recommended separation distance (d) in meters (m) can be determined using the equation applicable to the frequency of the transmitter, where (P) is the maximum output power rating of the transmitter in watts (W) according to the transmitter manufacturer.

NOTE 2: An additional factor of 10/3 is used in calculating the recommended separation distance for transmitters in the frequency range 0.15 MHz to 2.5 GHz to decrease the likelihood that mobile/portable communications equipment could cause interference if it is inadvertently brought into patient areas.

NOTE 3: These guidelines may not apply in all situations. Electromagnetic propagation is affected by absorption and reflection from structures, objects and people.

TSC / SERVICE / TRAINING / DISINFECTING / DISPOSAL

Training

B. Braun offers training and servicing. Please ask your local representative for further details.

Technical Safety Check / Service

The Technical Safety Check is required every 2 years and should be documented. Servicing work must be carried out exclusively by B. Braun trained personnel.

Check regularly

Check for cleanliness, completeness and damage. Use only according to this Instructions for Use. When changing sets on an interval basis (Ref. page 5) perform a power-on self-test. Check the following items each time the pump is powered on: self-test pass, audible alarms low/high pitch, and display illumination.

Cleaning and Disinfecting



Caution: Before cleaning and disinfecting the pump, always disconnect the pump from the patient, switch off the device and disconnect pump from AC power outlet and other devices (e.g. staff call).

Clean all external surfaces using a clean, soft, lint-free cloth dampened with a mild cleaning solution of soapy water. Make sure to remove any visible residue from all surfaces prior to disinfecting. The housing of Infusomat® Space, the line guide cover and the IV line guiding areas may be disinfected with EPA registered hospital disinfectants containing 1-propanol, isopropyl alcohol, ethanol or didecyl dimethyl ammonium chloride. Do not spray disinfectants directly on the pump, use a soft, low lint cloth dampened but not saturated with product. After cleaning and disinfecting allow device to dry for at least 20 minutes prior to use.

Chapter 9

Note: To clean and disinfect the peristaltic fingers and membrane, the line guide cover can be removed using a pointed object (ballpoint pen) inserted in the lower right corner. Clean cover and peristaltic fingers and membrane using a clean, soft, lint-free cloth dampened with a mild cleaning solution of soapy water. The line guide cover may be cleaned under running water after it is removed from the pump. Disinfect line guide cover, peristaltic fingers and membrane following same procedure as stated above.



Caution: Do not touch the peristaltic fingers and membrane area of pump with sharp object.

When reinserting the line guide cover, make sure that it is not damaged and that it audibly locks in place.

Note: Do not use chloride disinfectant products (bleach).

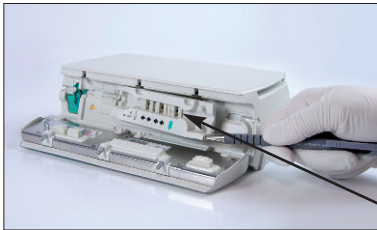

line guide cover

peristaltic fingers and membrane

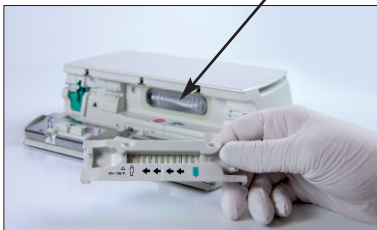

Note: Keep instrument upright and do not allow any part of instrument to become saturated with or submersed in fluid during cleaning operation.

Do not allow moisture or detergents to come into contact with the electrical connections of the device (P2 or P3 connectors) or any device openings. To reduce the likelihood of moisture ingress into the electrical connectors, the P2 connector of a power supply or combi cable may be used to cover the connections during cleaning operations. Ensure that any connectors used to cover are not connected to a wall outlet or other electrical source. Once the cleaning has been completed, remove the connector and inspect all connectors for residual moisture and evidence of damage or breakdown to the plating on the connectors. Allow any residual moisture to evaporate before plugging the device into a wall outlet. Replace any connectors which exhibit damage or evidence of plating breakdown prior to returning the device to service. Utilize electrical contact cleaner that does not react with plastics to remove any deposits of material which may be present inside the electrical connectors as required.



Caution: Do not allow liquids to enter into or come into contact with any openings or electrical connections on the pump or power supply. Fluid exposure in these areas may result in the risk of short circuit, corrosion or breakdown of sensitive electrical components, and/or electrical shock. If fluid exposure occurs, the device should be swapped out with another device in a manner that presents minimal interruption to patient care. The device should remain unplugged until it can be inspected by a trained technician for any evidence of damage and/or residual moisture which may impair the function of the device.

When reinserting the line guide cover, make sure that it is not damaged and that it audibly locks in place.



Caution: Do not touch line guide cover or peristaltic pumping area of pump with sharp object.

Note: The use of unapproved cleaners and failure to follow the disinfection procedures and the manufacturer's recommended dilutions can result in an instrument malfunction or product damage and could void the warranty.

Disposal

The pumps as well as battery packs can be returned to B. Braun for further disposal. When disposing of contaminated tubing as well as infusion solutions, please follow appropriate institutional regulations / guidelines.

Inspection on Delivery

Despite careful packaging, the risk of damage during transport cannot be entirely prevented. Upon delivery, please check that all items are present. Do not use a damaged device. Contact the service department.

Included in Delivery

Infusomat® Space, Battery-Pack SP, Instructions for Use manual.

INSTRUCTIONS FOR USE ACCESSORY

SpaceStation (8713140U)

Station for up to four pumps. For further information contact your B. Braun Representative or call B. Braun Customer Service at 1-800-627-7867.

SpaceCover Comfort (8713145U)

Cover to be placed on upper SpaceStation including built-in handle. The SpaceCover Comfort additionally includes a central alarm management and alarm LEDs.

Space Pole Clamp (speed clamp) (8713131)

Incorporates "speed clamp" for faster attaching/removing from IV Pole. A maximum of three B. Braun Space pumps can be stacked together when used with the Space Pole Clamp. For detailed instructions please refer to the "Overview Infusomat® Space" and "Patient Safety."

Power Supply SP (8713112D)

The Power Supply SP can supply power for a single pump.

- 1.) Connect P2 plug of Power Supply SP with P2 socket on back of pump (ensure that plug "clicks").
- 2.) Push power plug into wall outlet.

Note: To disconnect plug from pump, firmly grasp the connector and pull straight out. Do not twist or bend the cord or connector.



Caution: Do not pull on cord to remove connector.

A maximum of three plugs can be stacked upon each other in P2 socket.

Technical Data: 100 – 240V AC~, 50/60 Hz, 0,4-0,2A

Combi Lead SP 12 V (8713133)

The Combi Lead SP can connect up to three pumps. All pumps can then be operated via the Connection Lead SP (12 V).

- 1.) Connect plug of the Combi Lead SP 12 V with the socket P2 on the back of the pump.

- 2.) Connect plug of Connection Lead SP with Combi Lead SP.
- 3.) Push plug of Connection Lead SP into 12 V connector.

Note: A maximum of three plugs can be plugged into each other in socket P2.

Short Stand SP (8713135)

Use the Short Stand SP to attach an infusion container to the pump.

Caution: If the pump is used in combination with a short stand it must be positioned on a level surface. The short stand is only allowed to be used in conjunction with a plastic container of up to 1000 mL.

- 1.) Push the Pole Clamp on the pump.
- 2.) Plug the short stand into the aperture on the Pole Clamp; make sure that it audibly locks in.
- 3.) To remove the short stand: Press the white button at the lower end of the Pole Clamp and remove the short stand.

Interface Lead CAN SP (8713230)

Interface Lead CAN SP is needed in order to set up a connection between the SpaceStation/pump and the computer outlet (for service requirements).

- 1.) Push plug into socket F3 on the SpaceStation or P2 on the pump and connect with the CAN/USB converter.
- 2.) Connect CAN/USB converter to computer outlet as described in the Instructions for Use manual.

Caution: The Interface Lead CAN SP is only to be used by the service department; never use while patient is connected.

Note: A maximum of three plugs can be plugged into each other in socket P2.

Connection Lead SP (12 V) (8713231)

Install the Connection Lead SP (12 V) in the following way:

- 1.) Connect plug to socket P2 on back of pump or F3 on SpaceStation respectively.
- 2.) Put the connection lead into the car socket.
- 3.) If necessary, remove red adapter of motor vehicle connector by slightly turning and simultaneously pulling.

The green LED of the electronic box shows the operating voltage. The A/C connector can easily be replaced by another plug if required.

Note: A maximum of three plugs can be plugged into each other in socket P2.

Connection Lead for Staff Call SP (8713232)

To connect the Infusomat® Space to staff call, use the Connection Lead for Staff Call SP. The staff call needs to comply with the requirements of VDE 0834 (consider country specific regulations).

Note: Test staff call signalling before every use.

The Infusomat® Space offers three different staff call operating modes. They are displayed in the table on the following page. Consider staff call requirements when choosing an operating mode. Choose the operating mode via the service program.

Caution: The user should always closely observe the local pump alarms as well.

Note: A maximum of three plugs can be plugged into each other in socket P2.

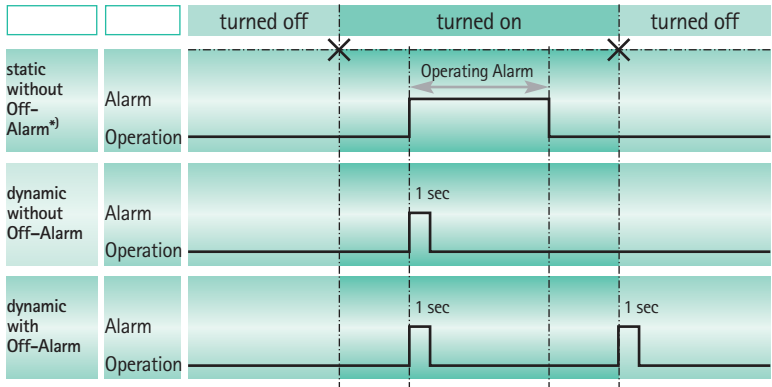

*) in the mode static without Off-Alarm, the staff call can be suppressed with 

Technical Data

	Connecting Wire	
		white and green
Alarm	disconnected	connected
Operation	connected	disconnected

Polarity is arbitrary:
max. 24 V / 0.5 A / 12 VA

SpaceStation MRI (8713152)

The SpaceStation MRI allows to use up to four pumps within the MRI Environment up to 20mT / 200 Gauss line. Refer to SpaceStation MRI Instruction for Use.

	Art. No.
B. Braun Infusomat® Space (100 – 240 V)	8713050U

Recommended accessories for the B. Braun Infusomat® Space:

SpaceStation.....	8713140U
SpaceCover Comfort.....	8713145U
Space Pole Clamp (speed clamp)....	8713131
Power Supply SP (US Plug)	8713112D
Combi Lead SP 12 V.....	8713133
Short Stand SP.....	8713135
Interface Lead CAN SP	8713230
Connection Lead SP (12 V)	8713231
Connection Lead for Staff Call SP	8713232
Space Station MRI.....	8713152

Technical Support

If the pump fails to respond to the operating or troubleshooting procedures listed in this manual and the cause cannot be determined, discontinue use and forward it to an authorized B. Braun Service Center.

Should it be necessary to return the pump for repair, contact Technical Support at B. Braun Customer Service at (800) 627-PUMP. A Returned Materials Authorization number will be provided. Carefully pack the pump (preferably in the original packing), and ship it prepaid to the address below. B. Braun cannot assume any responsibility for loss or damage to returned instruments while they are in transit.

Service and product performance information, operation training, service training, and service manuals may be obtained from the manufacturer by contacting:

B. Braun Medical Inc.

1601 Wallace Drive, Suite 150

Carrollton, TX 75006

Attn: Service Manager

or call (800) 627-PUMP

Product complaints may be sent to the Quality Assurance Manager at the above address.

With each complaint, please include:

- the pump's serial number and software revision,
- a description of the difficulty experienced,
- the pressure limit setting,
- the rate/dose setting,
- the initial volume(s) to be infused (VTBI),
- the type of fluid(s),
- the amount of time between the start of the infusion and the time the difficulty was noticed,
- the message displayed at the time the difficulty occurred,
- the catalog and lot number of the set(s) in use,
- the diagnostic code (if applicable), and
- any other information which might aid in the investigation of the complaint.

Authorization to return products must be received from B. Braun prior to shipment. Please contact Customer Service at the above phone number for a Returned Materials Authorization Number.

Clinical Support

The customer may speak with a Registered Nurse for clarification of operating instructions or clinical applications for the Space pump, etc.

A (Clinical Support Specialist) Nurse Consultant may be reached at (800) 854-6851.



Manufactured by
B. Braun Melsungen AG
34209 Melsungen
Germany

Tel +49 (0) 56 61 71-0

38911814 • Software G
1020

B. Braun Medical Inc.
824 12th Avenue Bethlehem,
PA 18018-3524 USA

Clinical and technical support for USA:

Clinical 1-800-854-6851

Technical 1-800-627-7867